

# Compounding WORLD



**NEW ADDITIVES FOR FLEXIBLE FILMS**

**ADVANCEMENTS IN PELLETISING SYSTEMS**

**PROTECTIVE PLASTICS IN ELECTRICAL SETTINGS**

# Compounding and Recycling Asia

18-19 March 2025 | Bangkok, Thailand

DISCOUNTED  
RATES OF \$145\*  
AVAILABLE

## One Event. Two Theatres.

Join us to meet representatives from the entire Asian plastics industry for networking and knowledge sharing

Compounding Theatre speakers include:



**Choprayoon  
Chulamanee**

Avient



**Prachaya  
Niyomthai**

SCGC



**Kalyanee  
Sirisinha**

Mahidol University



**Dr. Hanne Jones**

AMI

VIEW THE AGENDA AND SECURE YOUR PLACE

Sponsored by:



\*Subject to approval. This rate only applies to companies who carry out specific processes as their main business activity. Visit the website for more information. AMI reserves the right to cancel your booking if you select the wrong registration type.

# Compounding WORLD

## 5 News

News from the global plastics compounding industry: Envalior to locate new PPS facility in Germany; New APAC headquarters for Piovani; Geon takes over medical compounder; Hexpol to close US production site; Covestro expands US compound production.

## 17 Breaking through: additives for films

Additives are in the spotlight as requirements for packaging, agriculture, and other applications evolve. Innovations focus on sustainability and performance, writes Jennifer Markarian

COVER PHOTO: SHUTTERSTOCK

## 27 Protective plastics in electrical settings

New additives and masterbatches have been launched to meet the growing need for electrical conductivity in thermoplastic compound applications. Jennifer Markarian reports

## 41 Advancements in pelletising systems

New technologies and trends in pelletising equipment focus on energy reduction, automatic operation and pellet quality.

Chris Saunders reports on new products

## 52 Diary

## COMING NEXT ISSUE

› Twin Screw Extruders › Materials Testing › Special Effects › Long Fibre Thermoplastics



## CONTACT US

[CLICK HERE TO MAKE SURE YOU GET YOUR COPY](#)

# AMI

Ground Floor, One Brunswick Square,  
Bristol, BS2 8PE, United Kingdom  
Tel: +44 (0)117 924 9442  
[www.amiplastics.com](http://www.amiplastics.com)

[www.twitter.com/plasticworld](https://www.twitter.com/plasticworld)  
Registered in England No: 2140318

**DOWNLOAD MEDIA DATA**

### EDITORIAL

**Editor-in-Chief:** David Eldridge  
[david.eldridge@amiplastics.com](mailto:david.eldridge@amiplastics.com)

**Senior Staff Writer:** Chris Saunders  
[chris.saunders@amiplastics.com](mailto:chris.saunders@amiplastics.com)

**Contributing Editor:**  
Jennifer Markarian - [jma@amiplastics.com](mailto:jma@amiplastics.com)

**Events and Magazines Director:** Andy Beevers  
[andy.beevers@amiplastics.com](mailto:andy.beevers@amiplastics.com)

### ADVERTISING

**Advertisement Manager:** Claire Bishop  
[claire.bishop@amiplastics.com](mailto:claire.bishop@amiplastics.com) T/ +44 (0)7905 848744

**Head of Business Development:** Paul Beckley  
[paul.beckley@amiplastics.com](mailto:paul.beckley@amiplastics.com) T/ +44 (0) 117 311 1529

**Advertising Sales (China/Hong Kong):** Maggie Liu  
[maggieliu@ringiertrade.com](mailto:maggieliu@ringiertrade.com) T/ +86 13602785446

**Advertising Sales (Taiwan):** Ms Sydney Lai  
[sydneylai@ringier.com.hk](mailto:sydneylai@ringier.com.hk) T/ +886-913625628

**Advertising and Expo Sales (India):** Yogesh Vyas  
[yogesh@exhibetter.com](mailto:yogesh@exhibetter.com) T/ +91 9920735930

© Copyright Applied Market Information. No part may be reproduced without the prior written permission of the publisher.

AMI | Events

# Fire Retardants in Plastics

April 8-9, 2025 | Pittsburgh, PA, USA

Check out  
the full  
agenda!

Exploring new opportunities for the North American  
flame retardants industry

## Confirmed speakers:



**Dr. Hans  
Vercammen**

Division Director Specialty  
Chemicals,  
Campine



**Roger Avakian**

Owner,  
Avakian PolyChem  
Consulting



**Maggie Baumann**

President,  
Performance Polymers and  
Additives



**Dr. Boaz Turner**

Flame Retardant R&D  
Manager,  
TOSAF

**BOOK NOW**

Event sponsored by:



# Envalior to locate new PPS facility in Germany

Material producer Envalior has announced it will open a new polyphenylene sulfide (PPS) compounding facility in Uerdingen, Germany, with production slated to begin in the second half of 2025.

The facility will support growing demand for Envalior's PPS material Xytron, which first entered the market in 2016. Since then, the company says Xytron has gained prominence as it combines a strong set of properties including excellent chemical and hydrolysis resistance at elevated temperatures, extremely stable heat aging performance up to 240°C, very good electrical properties at elevated temperatures, low moisture absorption with high dimensional stability, and inherent flame retardance



IMAGE: ENVALIOR

## PPS compound production will start in H2 2025 at Envalior's facility in Uerdingen, Germany

that meets UL94 V0.

"Xytron is now widely recognised as one of the most high-performance, innovative, and sustainable PPS brands in the market," said Angela Zheng, Global Business Manager for Xytron at Envalior. "We are observing increased demand for Xytron, particularly from customers in Europe and

the Americas."

Zheng said Envalior's strategy for Xytron focuses on increased convenience and better service, including increased agility for new product development and technical support, enhanced sample availability, shorter lead times, and improved security of supply.

> [www.envalior.com](http://www.envalior.com)

# Perstorp buys precursors business

Specialty chemicals supplier Perstorp, a wholly-owned subsidiary of Malaysia's Petronas Chemicals Group, has acquired OQ Chemicals Nederland BV from OQ Chemicals GmbH. The Dutch business (formerly Oxea) manufactures

precursors for plasticisers and other products.

"With this acquisition of OQ Chemicals Nederland, we are further enabling our growth strategy and focus on the Specialty Chemicals sector as well as sustainable solutions," said Ib Jensen,

President and CEO.

The deal provides Sweden-based Perstorp with full ownership and control over all of the Dutch company's production assets, related technology, and employees.

> [www.perstorp.com](http://www.perstorp.com)

# Americhem R&D centre in India

Americhem has opened a new 1,200 m<sup>2</sup> research and development centre in Silvassa, India, offering specialised testing services for masterbatch colour development to customers across the region. Additionally, it will provide field and technical services to support customer-specific requirements.

The new laboratory aims to help Americhem expand into new markets and areas of business by offering enhanced capabilities for custom colour matching and faster response times. It is hoped this will attract new customers that prioritise speed and efficiency in their supply chain.

Toshan Simaiya, Americhem's Operations Director for India, highlighted the benefits of the new centre, noting that it will allow the company to be closer to customers, provide nimble support, faster colour development, and enable real-time communication and approvals.

The R&D centre began operations in late 2024, said Americhem.

> [www.americhem.com](http://www.americhem.com)

# Chroma Color acquires Spectra Color in US

Specialty colour and additive concentrate supplier Chroma Color has acquired US-based Spectra Color.

A custom manufacturer of colorants and pre-coloured resin compounds

located in Corona, California, US, Spectra Color serves a range of markets including wire and cable, packaging, healthcare, pharmaceutical, and consumer products. It also manufac-

tures a proprietary resin primarily made from LLDPE, predominantly used in the rotational moulding industry.

> <https://chromacolors.com>

> <https://spectracolorants.com>

## Dow aims for \$1bn in savings

US chemical company Dow has announced targeted actions to deliver \$1bn in cost savings, including a global workforce reduction of approximately 1,500 roles.

The initiative is designed to reduce Dow's costs in response to ongoing macroeconomic uncertainty and weaker-than-expected demand in key markets, including packaging and specialty plastics, while reinforcing its long-term competitiveness.

"While these decisions are difficult, we must continue to take proactive actions to reduce costs while we navigate through this ongoing slower-than-expected macroeconomic recovery," said Jim Fitterling, Dow chair and CEO. "As 2025 progresses we will continue to evaluate options to reinforce our competitiveness and take further action if necessary."

The workforce reduction follows a similar cost-cutting initiative in 2023 when the company eliminated 2,000 jobs to address economic uncertainty and comes amid reports of a Q4 2024 net loss of \$435m against a \$95m loss in the same period in 2023.

The company said it will record a charge of \$250m to \$325m in the first quarter of 2025 for costs associated with the plan.

➤ [www.dow.com](http://www.dow.com)

# Piovan opens new base in Asia-Pacific region

Italian company Piovan has invested €10m in a new facility in Suzhou, China, to boost its position in the Asia-Pacific region in the development and production of automation systems for plastics processing, along with food powders and refrigeration solutions.

"China is a market that the Group has always believed in by opening its first production site outside Italy 20 years ago," said PiovanGroup CEO Filippo Zuppichin. "We were convinced that China was becoming the manufacturing engine of the world. The facts and growth in recent years have confirmed this, and we are confident of future successes."



Image shows new €10m facility in Suzhou, China

The 15,000 m<sup>2</sup> premises will provide equipment, consulting, training, and after-sales service to subsidiaries in the group's APAC region, including Piovan Asia Pacific, Piovan Vietnam, Piovan Japan, Piovan Korea, Piovan

Indonesia, and Conair Asia in Taiwan and Singapore.

The group said the facility's emphasis will be on innovation and development projects plus an ongoing commitment to sustainability.

➤ [www.piovan.com](http://www.piovan.com)

## New owners for Mocom site

Polymer Solutions has acquired Mocom's former recycling site in Erlenbach, Germany. The Krall Kunststoff-Recycling subsidiary plans to use the existing recycling

lines, which have a total capacity of 5,500 tonnes/yr, to process polyamide from industrial sources and produce sustainable, high-quality recycled pellets

and regrind with a focus on transparent plastics such as polycarbonate and PMMA. It also specialises in technical plastics and the recycling of CDs.

"Our business partners will benefit from the many synergies resulting from the combination of the two companies," said Managing Director Jörn Bahr. "Together with Polymer Solutions, Krall can offer the entire cycle from collection and grinding to the delivery of ready-to-use recyclates from a single source and meet the growing demands of the market."

➤ <https://krall.de>

**Jörn Bahr, left, Managing Director of Polymer Solutions, and Louis Krall, authorised signatory of both Polymer Solutions and Krall Kunststoff-Recycling**



IMAGE: POLYMER SOLUTIONS

# ZSK Mc<sup>18</sup> COMPOUNDER. SUCCESS OF YOUR PROCESS. NO RISK.

- + Throughput champion due to the specific torque of 18Nm/cm<sup>3</sup>
- + Meets highest ZSK quality standards
- + Maximum flexibility in product changes and machine modifications
- + Wide area of applications
- + Highly energy-efficient operation



**SPE POLYOLEFIN CONFERENCE 2025**  
Galveston, TX/USA | Booth 112  
**February 16-19, 2025**

**PLASTIMAGEN 2025**  
Mexico City/Mexico | Booth 3214  
**March 11-14, 2025**

Coperion's ZSK Mc<sup>18</sup> high performance twin screw extruder is a superlative product. It has a proven track record on the market as a throughput champion for products with high torque requirements such as engineering plastics. For further information please visit [www.coperion.com/zskmc18](http://www.coperion.com/zskmc18)

 **coperion**

# Geon takes over US medical compounder

Geon Performance Solutions has acquired Foster Corporation, a specialist compounder of biomedical polymers headquartered in Connecticut, US. Foster currently operates three manufacturing locations and two distribution centres in the US, and employs approximately 200 people.

"Geon is the ideal partner to leverage Foster's strengths and augment its capabilities to better serve unique customer needs," said President and CEO of Foster Corporation, Larry Acquarulo. "We are proud that Foster's commitment to quality and innovation will live on with Geon."

This is Geon's fourth acquisition since 2020, and enhances Geon's participation in the high-value medical device market. Currently, Geon offers rigid and flexible PVC solutions,

PHOTO: FOSTER CORP



Cleanroom compounding at Foster Corporation

TPEs, and contract manufacturing services to healthcare customers. Its facility in Clinton, Tennessee, US, is ISO 13485:2016 certified, which is the medical industry's international standard for the manufacture of medical devices. Foster Corporation carries the same certification and offers formulation, develop-

ment, and production of custom medical compounds, implantable materials, engineered polymers, thermoplastic polyurethane elastomers, and polymer enhancements.

Foster's Connecticut plant occupies 47,000 sq ft of space and its Nevada facility has 20,000 sq ft of space.

> [www.geon.com](http://www.geon.com)

## IN BRIEF...

French recycler **Carbios** has launched a project to reduce expenses by reorganising and reducing its workforce by up to 40%.  
[www.carbios.com](http://www.carbios.com)

**Celanese** has appointed Scott Richardson, currently Chief Operating Officer, as Chief Executive Officer, effective 1 January 2025.  
[www.celanese.com](http://www.celanese.com)

**Covestro** has finished digitalising product-specific life cycle assessments (LCA) and expects the latest annual update of environmental data to be available in the second half of 2025.  
[www.covestro.com](http://www.covestro.com)

**Borealis** has signed a distribution agreement with Tegral Materials to expand the availability of its polyolefin solutions in Belgium, France, Germany, Luxembourg, and the Netherlands.  
[www.borealisgroup.com](http://www.borealisgroup.com)



IMAGE: BAUSANO

## Bausano starts machinery replacement program

Bausano has introduced the Reward Formula, which provides enhanced valuation for used MD series twin-screw extruders, incentivising their replacement with next-generation models.

The initiative allows customers to upgrade their installed machine fleet with immediate financial benefits, while promoting the circular economy and energy efficiency. Before collection, a team of Bausano Experts will assess the condition of the

extruder, offering up to 30% above market value for the machine. This creates a virtuous cycle, turning obsolete machinery into a valuable resource, according to the company.

"The goal is to offer our customers the opportunity to update their machinery and enhance the productivity of the plants according to a more eco-friendly business model," said Giorgio Critelli, Area Manager of Bausano.

> [www.bausano.com](http://www.bausano.com)



# On a roll...

**We're rolling out an array of performance additives for plastic film production.**

**For properties including slip, anti-block, wear resistance, and release, choose:**

- **MicroFLON® Micronized PTFE**
- **NanoFLON® Sub-micron PTFE**
- **Micronized Waxes for Plastics**

Order samples through our new website:  
**[www.ShamrockTechnologies.com](http://www.ShamrockTechnologies.com)**



Shamrock Recycles



# Hexpol to close US production site

Swedish compounding group Hexpol says it plans to shutter its production site in Kennedale, Texas, US, by the end of Q2 2025 and relocate all business to its other North American facilities.

The company says the changes are designed to improve efficiency in its operations and it will work closely with

customers to ensure a seamless transition.

Hexpol has also sold its production site in Muscle Shoals, Alabama, to private investment firm Karo Ventures with immediate effect. The site manufactured products outside of Hexpol's core business and had an annual turnover of around \$7m with a

profitability level below the target of the Hexpol Group, it said.

"These decisions are in line with our business model to focus on our core business, to optimise our efficiency and support our customers most effectively," said Klas Dahlberg, President and CEO, Hexpol Group.

> [www.hexpol.com](http://www.hexpol.com)

## EU bans BPA in food contact

Following a positive vote by EU Member States and a scrutiny period by the Council and the European Parliament, the EU Commission has opted to ban the use of Bisphenol A (BPA) in food contact materials due to its "potentially harmful health impact". BPA is used in the production of polycarbonate and other resins.

The ban means BPA will not be allowed in products that come into contact with food or drink, such as the coating on metal cans, reusable plastic drink bottles, water coolers, and other kitchenware, and takes into account the latest scientific assessment from the European Food Safety Authority (EFSA).

EFSA concluded that BPA, which is already banned in the EU for infant bottles, had potentially harmful effects on the immune system.

For most products, there will be an 18-month phase-out period.

> [www.efsa.europa.eu](http://www.efsa.europa.eu)

## Lati compound selected by food industry supplier

German conveyor belt manufacturer Forbo Movement Systems has selected Lati's detectable compound for its high-performance food industry solutions.

In a press release, Lati said achieving a solution that met the stringent requirements of the food industry was "no easy feat," with the challenge laying in developing a compound with the required magnetic detectability for plastic parts, a critical feature for ensuring safety and preventing contamination.

The required level of magnetic detectability was eventually achieved, and the



material offers a host of other benefits applicable to the food industry, including enhanced durability, resistance to chemicals and mechanical stress, compliance with food safety regulations, and a high visibility blue colour standard which adheres to

the industry's widely accepted practices.

In 2025, Lati is celebrating the 80th anniversary of its founding. The Italian company has been certified as a Historical Brand of National Interest.

> [www.forbo.com/movement](http://www.forbo.com/movement)  
> [www.lati.com](http://www.lati.com)

## French recycling approval

The European Commission has approved, under EU State aid rules, a €500m French scheme to support investments for the chemical recycling of certain types of plastic waste such as trays, films, non-beverage bottles, and textile materials with a certain amount of

polyester content.

The scheme will contribute to the EU's objective of circularity of production and consumption processes as part of a broader shift towards climate neutrality.

The Commission has deemed the scheme "necessary and appropriate"

to allow for the deployment of chemical recycling of plastics.

The Commission said the new scheme is expected to have an incentive effect as the beneficiaries would not carry out the relevant investments without public support.

> <https://commission.europa.eu>

# COMPLETE SYSTEM

COMPEO compounding technology  
– the heart of customized systems.



## Complete Compounding Solutions

BUSS is a worldwide leader in providing complete solutions for demanding compounding applications. With a long history of meeting the needs of a diverse customer base, BUSB offers expert consultation, planning, engineering, and innovative products. The COMPEO as the heart of the compounding line ensures maximum performance and unrivaled flexibility resulting in superior product quality.



# RACE<sup>TM</sup>

RECYCLING AND COMPOUNDING EXPO

COMPOUNDING  
WORLD EXPO  
INDIA

PLASTICS RECYCLING  
WORLD EXPO  
INDIA

14-15 May 2025 | Mumbai, India

REGISTER  
FOR FREE

## SECURE YOUR FREE VISITOR PASS TO:



Explore materials and solutions for current and future projects



Join discussions on industry challenges and opportunities



Elevate your knowledge with our free conference programme



Network with like-minded international professionals



Benefit from the crossover of the co-located expos

Brought to you by:

**POLYMERUPDATE**  
INTELLIGENCE ANALYTICS CONFERENCE

**AMI**

Industry alliance partner:

**CPMA**  
Council of Plastics Manufacturers of India

Association partners:

**spe**  
INDIA

**OPP**  
Organization Of  
Plastic Processors Of India

**PMMAI**  
Plastic Manufacturers  
Association of India

**IPCC**

**IPCC**

**INDIAN PLASTICS INSTITUTE**

# Covestro expands PC compound production in US

Polycarbonate producer Covestro is expanding its site in Hebron, Ohio, US. The expansion is seen as an important step in meeting growing demand in the automotive, electronics, and healthcare industries in North America.

The “low triple digit million Euro” investment will see the construction of multiple new production lines and infrastructure to manufacture customised PC compounds and blends, significantly expanding capacity in the Solutions & Specialties business.

“With this expansion, we can meet our customers’ growing demand for specialised polycarbonate materials, grow together with our customers, and strengthen our position as a leading provider of polycarbonate

materials in North America,” said CTO Thorsten Dreier. “The move also aligns with our strategy to produce in the region for the region, to manufacture close to our customers and ensure reliable supply.”

Construction is scheduled to begin in 2025, with operations starting by the end of 2026.

Covestro already has an established R&D centre in Pittsburgh and is now doubling down on its US compounding capabilities. In future, both facilities will work closely together to support major transformation processes, such as the electrification and automation of mobility, sustainable developments, and digitalisation.

➤ [www.covestro.com](http://www.covestro.com)

## EURIC calls on EU for end-of-waste criteria

The EU’s proposed Circular Economy Act - which has been announced by Jessika Roswall, the new Commissioner for Environment, Water Resilience and a Competitive Circular Economy - aims to create market demand for recycled materials and establish a single market for waste.

In response to the announcement, the European Recycling Industries’ Confederation (EURIC) said the development and introduction of harmonised end-of-waste (EoW) criteria for plastic waste, in accordance with Article 6 of Directive 2008/98/EC, is essential in achieving a truly circular economy in Europe.

“EU-wide EoW criteria, specifying when plastic waste ceases to be

waste, is imperative and essential to create a level playing field, eliminate market barriers, and foster trust in recycled materials,” the organisation said in a joint statement with FEAD, EERA and Plastics Recyclers Europe. “This is particularly important in the current context of low demand of recycled plastic and low prices of virgin plastic, together with ambitious recycled content targets. Moreover, the new waste export rules, banning plastic waste exports to non-OECD countries as of 2026, will create a surplus of waste available in the EU, which will intensify the need for a strong internal EU market for recycled plastics.”

➤ <https://euric-aisbl.eu>



**GERMANY**  
 Contacts: Lily  
 Telephone: +49-17680761534  
 Email: yue.lizhi@gmail.com

**USA**  
 Contacts: John Ding  
 Telephone: +1-826-244-6105  
 Email: dingjashen@hotmail.com

**CHINA**  
 Contacts: 曹先生  
 Telephone: +86-13342991348  
 Email: China\_520@126.com  
 Fax: 0555-2221146

Contacts: 潘小姐  
 Telephone: +86-13855504033  
 Email: jiangyini13855504033@generalplastics.com  
 Fax: 0555-2221146

Http: //www.rgd.com Http: //www.nuaji.com  
 Wanshan Gendre Machinery Manufacturing Co., Ltd

# AMI

# Events

Our conferences are designed to inspire ideas, promote meaningful conversations and build long-lasting relationships.

## 50+

FOCUSED EVENTS IN THE UK,  
EUROPE, NORTH AMERICA AND  
ASIA EACH YEAR

ATTRACTING OVER

## 5,000

PLASTICS INDUSTRY PROFESSIONALS

### Why attend?

- ✓ Network with industry professionals
- ✓ Exchange ideas with like-minded and experienced people
- ✓ Gain valuable industry insights
- ✓ Discover new business leads
- ✓ Get inspired with innovative ideas

Each year, AMI events connect industry leaders from across the global plastics supply chain.

Want to see which events are coming up in our partner industries and your region? Take a look below and click on the event region to find out more.

- ▶ [Agricultural Film](#) - [Europe](#) / [North America](#)
- ▶ [Bioplastics](#) - [North America](#)
- ▶ [Cables](#) - [Europe](#) / [Asia](#) and [Polymers in Cables](#) - [North America](#)
- ▶ [Chemical Recycling](#) - [Europe](#) / [North America](#)
- ▶ [Compounding and Recycling](#) - [Asia](#)
- ▶ [Feedstocks for Plastics Recycling](#) - [Europe](#)
- ▶ [Fire Resistance in Plastics](#) - [Europe](#) and [Fire Retardants in Plastics](#) - [North America](#)
- ▶ [Masterbatch](#) - [Europe](#) and [Thermoplastic Concentrates Forum](#) - [North America](#)
- ▶ [Medical Tubing and Catheters](#) - [Europe](#) / [North America](#)
- ▶ [Performance Polyamides](#) - [North America](#)
- ▶ [PFAS](#) - [Europe](#) / [North America](#)
- ▶ [Plastics in Electric Vehicles](#) - [Europe](#)
- ▶ [Plastics Recycling Technology](#) - [Europe](#) / [North America](#)
- ▶ [Polyolefin Additives](#) - [Europe](#)
- ▶ [Polymer Sourcing and Distribution](#) - [Europe](#)
- ▶ [Polymer Engineering for Energy](#) - [Europe](#) and [Polymers in Energy](#) - [North America](#)
- ▶ [Polymers in Flooring](#) - [Europe](#) / [North America](#)
- ▶ [Polymers in Hydrogen and CCUS Infrastructure](#) - [Europe](#)
- ▶ [Polymers in Footwear](#) - [North America](#)
- ▶ [Polymers in Roofing](#) - [Europe](#)
- ▶ [Recyclable Flexible Packaging](#) - [Europe](#)
- ▶ [PVC Formulation](#) - [Asia](#) / [Europe](#) / [North America](#)

Let us know which events you are interested in

# We produce customer-focused projects with R&D and innovation based on sustainability

Tisan Engineering Plastics, which has been operating in the engineering plastics sector for many years, focuses on innovation and distinctive studies and creates added value and difference with the vision of developing substitute products for imported products with the accumulation of knowledge gained in the studies it carries out on different polymers. Our R&D structure has adopted the goal of creating scientific and economic benefits with sustainable projects by diversifying studies in various product groups in the areas that the sector needs and most importantly in the future with university-institution collaborations.

In recent years, especially in the automotive sector, which started with the green transformation approach, the increase in demand for electric vehicles, lightweighting studies to reduce fuel consumption, carbon footprint, environment and sustainability within the framework of recycling products to be returned to the economy at higher rates, and approaches that include legal obligations such as the return of recycled products to the economy, focus on solutions that meet basic requirements by considering cost effectiveness with our R&D department consisting of 22 personnel as engineers with different disciplines and PhD and Master's degrees.

As a result of our R&D studies, maleic anhydride grafted polymer materials that we developed under the Olebond® brand, which has a very wide sub-product portfolio used as compatibilizer and binder in polymers, were offered to our customers in order to meet the needs of the sector in a very special area.

Maleic anhydride grafted polymer is a special polymeric structure that can be used in almost all polymer structures. Its compatibilizing feature that prevents phase separation when different polymers are blended to obtain different technical properties, its binding feature

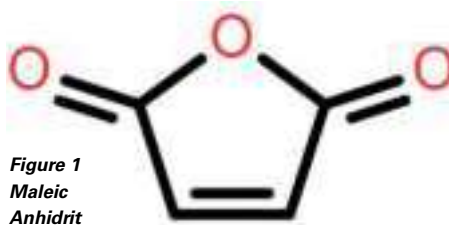

Figure 1  
Maleic  
Anhidrit

that ensures that the fillers added to the polymers to improve technical properties are completely mixed into the polymer and integrated with the polymer, and its impact modifier feature that improves the toughness of polymers.

As a result of our R&D studies, our EVA-graft, ULDPE-graft, LLDPE-graft, PP-graft, ABS-graft Olebond® products, which we have been developing with reactive extrusion technique and offering to the plastic-polymer sector for about 7 years, offer the best solution to the demands of our customers in our country and abroad.

Our Olebond® products cover a wide range of products that appeal to sectors including blend-containing polymers, filled polymers, composite pipes, oxygen barrier multilayer pipes, composite panels, halogen-free flame retardant cables, metal coating, co-extrusion, cast and blown films and recycling.

Our commercial products in this field, OLEBOND 7401 HH, with its binding and compatibilizing properties in the polypropylene group, ensures that the fillers added to the compound are

distributed homogeneously within the polymer and that there is perfect adhesion between the polymer and the filler thanks to the maleic anhydride active groups.

As impact modifiers, OLEBOND 7403 IM-Z, which we have developed especially for the polyamide product groups, is intended for use under normal conditions, and OLEBOND 7403 IM-C is our impact modifier product suitable for providing high performance even at very low temperatures.

OLEBOND 7404 is suitable for use in filled ABS or PC/ABS blend products with its binding and compatibilizing properties, prevents phase separation of fillers or polymers, and contributes to the development of technical features.

OLEBOND 7402 CW provides high strength adhesion suitable for use in products such as PE based, oxygen barrier multilayer pipes, composite panels, halogen-free flame retardant cables, metal coating, co-extrusion, cast and blown films.

Our products have become a brand that is shown as a competitor to global manufacturers today with increasing awareness and quality. Tisan always continues to innovate, studies on similar products with bio, recycling, or monomers with different thermal temperature resistances, taking into account sustainability and environmental effects.



Contact Tisan Engineering Plastics at:

[tisan@tisan.com.tr](mailto:tisan@tisan.com.tr) | [www.tisan.com.tr](http://www.tisan.com.tr)



*Additives are in the spotlight as requirements for packaging, agriculture, and other applications evolve. Innovations focus on sustainability and performance, writes Jennifer Markarian*

# Breaking through: additives for flexible films

Flexible plastic films have a wide range of uses in packaging, stretch wrap and shrink film, agriculture, and more. With food and non-food packaging as key markets, film design and use are affected by new regulations, such as the EU's Packaging and Packaging Waste Regulation (PPWR). New and potential upcoming restrictions in multiple geographic regions on specific additive substances, such as PFAS, are also affecting film formulations.

The PPWR received final approval from the European Parliament in late November 2024, and its rules for the EU include requirements for packaging to be reusable or recyclable by 2030, minimum recycled content standards for plastic packaging, and requirements for packaging to minimise weight and volume. Design for recycling criteria are due to be established by 2028, and by 2030, recyclability will be described by performance grades (A, B, and C) based on the

weight percentage of the package that is recyclable.

Design for recycling has an important role to play in guiding the industry, said Susannah Owen, AMI Consultant specialising in Flexible Films, in a video [interview](#). In the biaxially oriented film industry, for example, the whole value chain - including materials suppliers and equipment manufacturers - worked together to bring oriented polyethylene (OPE) films to market, where it offers a solution for monomaterial packaging. In the biaxially oriented polypropylene (BOPP) space, there are now monomaterial solutions available even for challenging applications, such as coffee and stand-up-pouches, Owen said. She added that the market is already seeing a shift toward monomaterial flexible packaging formats, such as pouches, which will help meet PPWR requirements.

New additives are providing benefits for monomaterial film structures.

**Main image:**  
Young melon  
plantation  
mulching

**Right: Void Technologies and Berry Global launched an all-PE film designed for recycle-ready pet-food packaging using VO+ technology**

**Voiding agents**

**Void Technologies** offers its patented VO+ voiding technology additive as a masterbatch to create nano- and micro-scale air pockets in machine direction orientation (MDO) or biaxially oriented blown or cast films. The voids reduce density, increase opacity, and improve yield, tensile strength and puncture resistance. The company says the technology can be used in polyolefins and polyesters. So far, it has been most developed in polyethylene films, where it can be used to make opaque, all-PE packaging in compliance with food contact standards. PE films made with this technology can be an alternative to pearlized BOPP.

The VO+ PE 1300 Series Voiding Agent has achieved recyclability certifications from Europe’s RecyClass and the US Association of Plastics Recyclers that indicate its compatibility in PE film recycling streams.

Void Technologies partnered with film producer Charter Next Generation (CNG) to introduce recycle-ready cavitated PE films for flow wrap and confectionery applications, the companies announced in early 2024. The companies said that the MDO PE films created a combination of low density and high opacity that could not be



IMAGE: BERRY/VOID

achieved with calcium carbonate cavitation agents or with titanium dioxide pigments.

In December 2024, Void Technologies and **Berry Global** launched an all-PE film designed for recycle-ready pet-food packaging using VO+ technology. “Pet food applications present unique challenges due to demanding physical and organoleptic requirements, and this highlights the individual capabilities of both Berry and VOID, but more importantly, the power of our combined expertise,” said Caleb Triplett, Berry’s Director of Product Management, Flexible Packaging.

As manufacturers move to monomaterial packaging films that eliminate separate materials used as barrier layers, alternative ways to improve barrier become more important. **Milliken’s** latest Ultraguard 2.0 masterbatch improves barrier performance in HDPE by up to 70%, the company reports. The company says that the additive enables “structural realignment” that slows transmission of oxygen, moisture and other permeants. Applications include cereal liner film and flexible pouches.

**PFAS response**

Plastic additives are regulated, but some types of additives have been in the spotlight with calls for increased regulation or even bans. In particular, per and polyfluoroalkyl substances (PFAS), are facing increasing restrictions. The fluoropolymer-based processing aids used in some film applications to prevent problems such as melt fracture or die-lip buildup during processing are set to be classified as PFAS. As a result, several additive suppliers and masterbatch producers have introduced PFAS-free processing aids as alternatives (see *Compounding World* April 2024).

Most recently, **Clariant** launched the AddWorks PPA line of PFAS-free processing aids for polyolefin films. The additives are also free of silicone or siloxane, and have high thermal stability and low migration tendencies, the company reports. The additives are currently targeted for LLDPE blown films for packaging and agriculture, and they may also be useful in cast films. Clariant plans to create several products in the product range that are specific to certain applications and regions. For example, AddWorks PPA 122 G, a processing aid masterbatch for polyolefin film extrusion that the

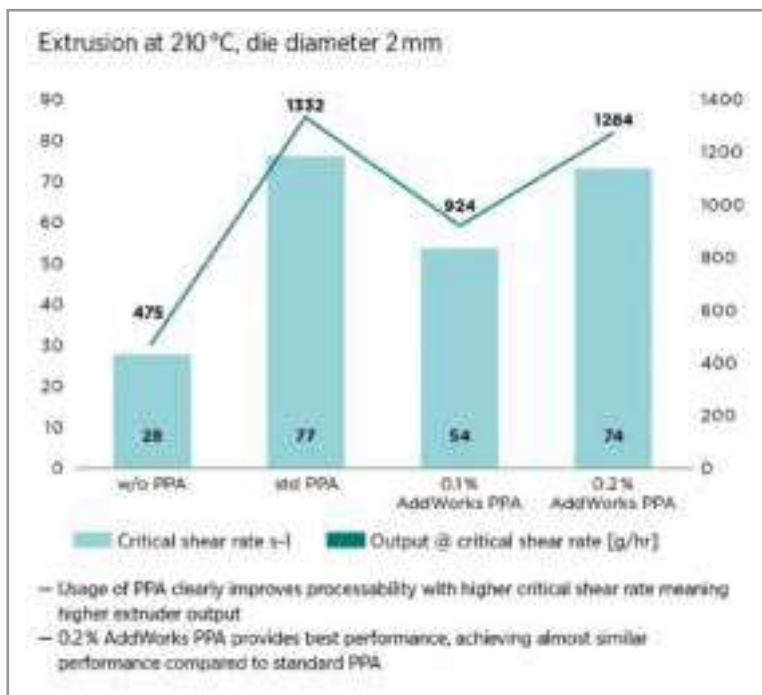

**Critical shear rate**

Source: Clariant

# The New Generation of Mixer



## CONTAINER MIXER **i4.**

Excellent mixing flexibility, high quality  
and ease of cleaning.

Its **DISTINGUISHING FEATURES**



Equipped with the MIXACO Control Center (MCC), we set another milestone  
for highly efficient mixing plants.



Even shorter cleaning  
times thanks to new  
machine components



Innovative injection of  
liquids through  
the shaft



One mixer for container  
sizes 300, 450 & 600 or  
800, 1000 & 1300 liters



Maximum flexibility &  
optimal homogenization  
without material  
build ups



High energy efficiency  
through the use of  
frequency controlled  
energy saving motors



Excellent mixing quality  
with short mixing times  
& minimal heating

**MIXACO**

Dr. Herfeld GmbH & Co. KG  
Niederheide 2 - 58809 Neuenrade - Germania  
Tel. +49 2392 9644-0 - Fax +49 2392 62013  
info@mixaco.de

**MIXACO USA LLC**

1784 Poplar Drive  
Greer, SC 29651 - USA  
Tel. +1 864 331 23 20 - Fax +1 864 331 23 21  
info@mixaco.com

[MIXACO.COM](http://MIXACO.COM)

**made in  
germany**



AMI | Events

# Cables

11-13 March 2025 | Düsseldorf, Germany

The  
countdown  
is on book  
today!

Promoting innovation  
for polymeric  
materials  
in European wire  
and cable

## Speakers include



**Brita Kunze**  
Sales Director  
Masterbatch  
Division,  
**Delta Tecnic**



**Dr. Michael Heinz**  
Manager Global  
Materials  
Development,  
**Corning Optical  
Communications**



**Leo Nijhof**  
Global Technical  
Development  
Manager,  
**Nouryon**



**Alessandra Missiroli**  
Technical Support  
and Development  
Manager,  
**Cabot Corporation**



**Kiran Santhosh**  
Application  
Manager,  
**Premix**

Headline sponsor

Also sponsored by:



melos



Check out the agenda

# BOOK YOUR PLACE TODAY

company says is based on Clariant’s proprietary organic materials, is available in Asia-Pacific and greater China. Other new products will be launched in 2025 for EMEA and the Americas.

**Dover Chemical** announced that the European Food Safety Agency (EFSA) has published a safety assessment endorsing its antioxidant Doverphos LGP-12 (liquid green phosphite) for EU food contact. The company says that the antioxidant has a cleaner toxicology profile than traditional phosphite stabilisers and has been designed with “future compliance” in mind, as regulatory bodies increase scrutiny of human health effects from additives and their degradation products. The additive is a high molecular weight polymeric phosphite and its high phosphorus content allows it to be used at lower loading levels, both of which contribute to low migration. The additive received US FDA clearance for food contact in LLDPE in 2019 and for HDPE in 2023. The company reports that it has submitted requests for food-contact approval from other major global regulatory bodies.

LGP-12 also acts as a PFAS-free and silicone-free polymer processing aid (PPA), showing both the ability to clear melt fracture in blown film and to

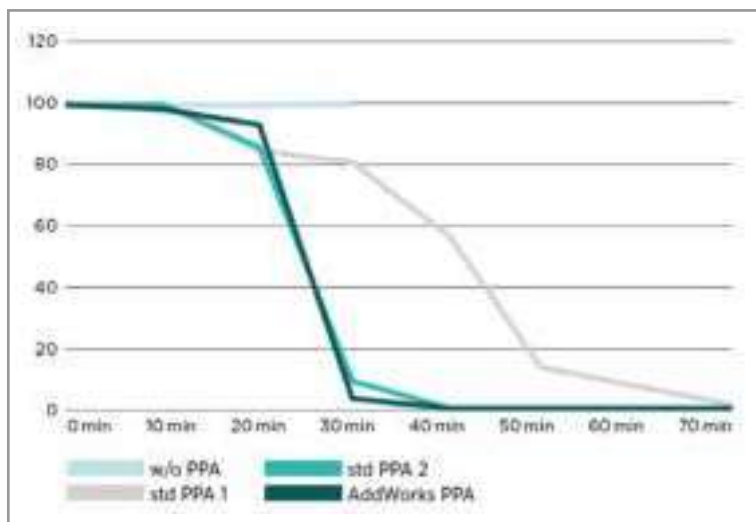

Percentage of sharkskin on films

Source: Clariant

reduce die-lip buildup in cast film. PPAs from Dover Chemical available in masterbatch form with an LLDPE carrier include Doverclear 840 for resins with a melt index greater than one, and Doverclear 841 for resins with fractional melt indices. The PPAs are typically used at 0.5-2.5% in the final product, and they are also available in other carrier resins.



## Imerys Graphite & Carbon

Premium carbon based solutions for thermal management, electrical conductivity and electromagnetic shielding.

**C-THERM™**  
HIGH ASPECT RATIO GRAPHITE

- Low loading
- Formulation flexibility
- Improved processing

**ENSACO®**  
CONDUCTIVE CARBON BLACK

- Low loading
- Easy dispersion
- Low moisture pick-up

**TIMREX®**  
GRAPHITE

- High thermal conductivity
- High electrical conductivity
- Lubrication effect
- Superior purity

Contact us at [imerys.com](https://www.imerys.com)

IMAGE: BASF



**Above: BASF's Tinuvin NOR 211 AR additive is a heat and light stabiliser launched to protect films used in intensive horticulture**

LGP-12 has also been finding success as a stabiliser in recycle streams, where it has been shown to reduce both the size and overall amount of gels in recycled-polyethylene film applications.

### Additives for recycling

As recycled content increases, plastic compounds will need to be stabilised to withstand multiple processing cycles without creating gels that can cause holes or breaks in film webs. For example, Clariant's PKG 196, introduced at the K2022 Show, helps reduce gels and allow higher levels of recycled content in thin films and flexible packaging, the company reports.

**BASF's** IrgaCycle products, first launched in 2021 and including products such as IrgaCycle PS 031 G for recycled LDPE and LLDPE in films, are additive blends designed specifically for improving the properties of recycled plastics.

**Nexam Chemical's** Reactive Recycling technology uses reactive chemistry to improve the processing properties of recycled PE and PP. In a study conducted in 2024, the Nexamite additive was able to prevent breakdown when added to PP and to restore the molecular weight when added to a simulated post-consumer recycled PP.

Compatibilisers also play a key role in allowing recycled content in film applications by improving homogeneity in batches with materials of different polarities and flow properties. For example, the new MaxiLoop product family from **Gabriel-Chemie** includes the MaxiLoop HP7AB4780COM Compatibiliser Masterbatch that can be used to help compatibilise edge trims from film extrusion in the production of multilayer products, which may contain both non-polar polymers (eg, PE or PP) and polar polymers used as barrier layers (eg, PA6, PA66, or EVOH).

Use of compatibilisers in recycling of multilayer

films was discussed in more detail in the May/June 2024 issue of *Compounding World*. The additives are finding use for both post-industrial and in-house recycling of barrier film scrap as well as preparing films in the post-consumer recycling stream.

### Blockers and stabilisers

Ultraviolet (UV) absorbers or light blocking additives may be used in packaging to protect contents from UV degradation. Conventional UV blockers have included those based on benzotriazoles, but since some phenolic benzotriazoles have been added to the European Chemical's Agency candidate list of Substances of Very High Concern (SVHC), alternatives that are not on the SVHC list are being considered. **Ampacet's** UVBlock 1496 is an alternative that offers UV barrier performance in the low UVA and UVB wavelength range, the company says. It is approved for food-contact applications in Europe and the US.

Agricultural applications, such as films used in greenhouses, have stringent stabilisation requirements, because the films must withstand both weathering and the increasing use of inorganic chemicals in agriculture. The latest from BASF is Tinuvin NOR 211 AR, a heat and light stabiliser to protect films used in intensive horticulture under severe UV radiation and the presence of high levels of sulphur and chlorine. These films are being designed for greater durability, which improves sustainability by reducing plastic waste.

"The Tinuvin NOR 211 AR additive solution addresses a broad variety of challenges for agricultural plastics, including sustainability requirements, increased chemical exposure, longer use durations and downgauging trends," said Bettina Sobotka, Head of Global Marketing and Development for Plastic Additives at BASF. "BASF's NOR [non-basic aminoether] HALS [hindered amine light stabilisers] solutions improve stabilisation by moving beyond solutions based on secondary and methylated HALS. Through collaboration with agricultural plastic producers as well as farmers, we facilitate the exchange of knowledge and expertise, creating solutions that will ultimately lead to improved crop yield."

The new stabiliser is part of BASF's Valeras portfolio, which the company says is designed to help users meet their sustainability goals. Renewable electricity is used to manufacture the additive, and the product form improves material dosing precision, among other benefits, the company says.

CJWS SUPER-HIGH TORQUE SPECIAL  
EQUIPMENT FOR MODIFICATION



SUZHOU JWELL MACHINERY CO.,LTD.

Add: No.18, Dong'an Road, Taicang, Suzhou city, China  
Tel: +86-139 1887 6278 E-mail:salat@jwell.cn

[www.jwell.cn](http://www.jwell.cn)  
[sales@jwell.cn](mailto:sales@jwell.cn)



# AMI | Events

## Masterbatch

17-18 June 2025 | Málaga, Spain

Sponsored by:



Exploring the latest in innovation and market prospects for the  
masterbatch sector

### Confirmed speakers:



Valeria Branca  
Project Manager  
EXPRA



Paul Dietz  
Group Technical  
Director  
FP Pigments



Luis Roca Blay  
Leader of  
Compounding  
AIMPLAS

# SECURE YOUR PLACE

# PVC Formulation

February 25-26, 2025 | Cleveland, OH, USA

Explore local and global trends in the PVC industry to optimize your business and add value to your formulations

Listen to industry leaders including:



**Bridget Confait  
Smith**  
Westlake



**Bill Blackstock**  
Resilient Floor Covering  
Institute (RFCI)



**Li Xi**  
McMaster University



**Lilia Orozco**  
Orbia Polymer  
Solutions - Alphagary



**Tony Vella**  
Vision Extrusions



**Noble Francis**  
Sanitized USA



**Michael Marange**  
BTR Flooring and  
Recycling



**Richard Krock**  
VyChlor Advisors

Sponsored by:

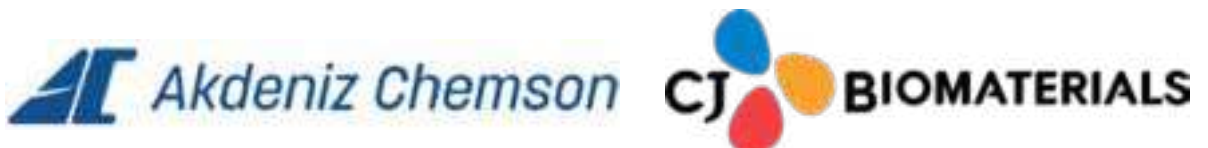

LAST CHANCE TO BOOK! SECURE YOUR PLACE TODAY



# Amcor wins Dow packaging award

**Amcor's** AmPrima recycle-ready coffee packaging was recognised by the 35th Packaging Innovation Awards, which are sponsored by **Dow**.

"Our AmPrima Plus was the perfect solution for Nordic coffee leader Kjeldsberg, with whom we won this award. It is a mono-PE pouch that offers a high barrier to prolong the freshness of coffee. It runs seamlessly on coffee roasters' packing machines and is readily recyclable in most European countries as certified by Institute cyclos-HTP," said Giorgio Dini, Marketing Manager EMEA for Coffee at Amcor.

The package was designed in accordance with the Circular Economy for Flexible Packaging (CEFLEX) guidelines, and it helps brands move to a mono-material solution that allows for easy recycling.



Clariant has introduced light stabilisers specifically for agricultural films: Addworks AGC 102G for greenhouse films and Addworks AGC 970G for mulch film applications. Eliandro Felipe, Head of Sales Americas for Additives Polymer Solutions at Clariant, said that greenhouse films are being designed to last three to five years in the field, with increased UV exposure and increasing use of harsh chemicals. Addworks AGC 102G is used to help prevent premature degradation as well as to reduce haze and maintain film transparency.

**Techmer PM's** custom UV stabiliser packages for agricultural film are designed to allow films to last in the field for the growing season and retain tensile properties in extreme environments. The company has also designed UV products for compostable films, which are meant to be installed in the field and used for a year, with the additive tailored specifically for a region, growing season length, and film thickness. Depending on the application, UV packages are designed for various environmental exposures, including pesticide chemicals commonly used in the agricultural industry that standard UV packages cannot survive, the company claims.

## Antiblocks

Antiblocking agents, including minerals such as talc, are often used in films to prevent layers from sticking together. In PE films, talc offers a good balance of film surface roughness, transparency, and minimal slip agent interaction, says **IMI Fabi**, which introduced a new talc developed specifically for this application. NoBlock-S is an efficient

antiblocking additive characterised by easily dispersible spherical agglomerates, which provide dust-free, high flowability, the company says. The product meets stringent requirements for preventing dust development in industrial environments and in manual handling.

**Cargill's** bio-based Optislip is a new brand name for the company's product line, which is available in pastille, bead, microbead and powder or as a masterbatch and can be used in polyolefin and biopolymer films. The additive migrates to the surface to provide a lubricating surface layer. The company says benefits include easier processing and improved film quality, smoother film winding and unwinding, and reduced blocking in bag applications. Different products provide high slip, medium or controlled slip (particularly for laminated or coextruded films), and low slip and antiblock.

## CLICK ON THE LINKS FOR MORE INFORMATION:

- > [www.voidtechnologies.com](http://www.voidtechnologies.com)
- > [www.berryglobal.com](http://www.berryglobal.com)
- > [www.milliken.com](http://www.milliken.com)
- > [www.clariant.com](http://www.clariant.com)
- > [www.doverchem.com](http://www.doverchem.com)
- > [www.basf.com](http://www.basf.com)
- > <https://nexamchemical.com>
- > [www.gabriel-chemie.com](http://www.gabriel-chemie.com)
- > [www.ampacet.com](http://www.ampacet.com)
- > [www.techmerpm.com](http://www.techmerpm.com)
- > [www.imifabi.com](http://www.imifabi.com)
- > [www.cargill.com](http://www.cargill.com)
- > [www.amcor.com](http://www.amcor.com)
- > [www.dow.com](http://www.dow.com)

AMI | Events

# Plastics Recycling Technology

June 10-11, 2025 | Long Beach, CA, USA

Mechanical recycling in North America - developments in sorting, processing and applications to improve sustainability and profitability

## Speakers include



**Scott Saunders**  
General Manager  
KW Plastics Recycling Division



**Silke Einschuetz**  
Senior Consultant,  
Recycling &  
Sustainability  
AMI



**Chris Max**  
Sustainable  
Innovation  
Packaging Lead  
Kraft Heinz Company



**Adam Wozniak**  
Senior Managing  
Director of  
Sustainability  
Ravago

**BOOK YOUR PLACE TODAY**

Sponsored by:



# Protective plastics in electrical settings

*New additives and masterbatches have been launched to meet the growing need for electrical conductivity in thermoplastic compound applications. Jennifer Markarian reports*

With the continuing electrification of transportation, manufacturing, and other areas, the need for electrically conductive thermoplastics is more important than ever. Additives are crucial for making thermoplastics fit-for-purpose in antistatic and electrostatic discharge (ESD) protection applications as well as conductive grades for metal replacement. Electromagnetic interference (EMI) shielding for electronics and sensors, such as those used in electric vehicles, is also a key property.

A wide range of additives are used to create conductivity, from conductive carbon black to carbon nanotubes and graphene. Proper dispersion is crucial for conductivity, and either masterbatches or fully formulated compounds are typically used to achieve the needed dispersion.

"The demand for conductive thermoplastic compounds is expanding across several industries, with notable growth in the packaging as well as cable industry," said Alexandra Megally, Marketing, Strategy and Sustainability Manager, at **Cabot**. "These sectors are driven by the increasing need for safer transport, handling, and storage of materials, as well as evolving trends in renewable energy distribution and digital transformation. Key



IMAGE: SHUTTERSTOCK

requirements in these areas emphasise protection from electrostatic discharges, compliance with tightening safety regulations, and ensuring reliability in critical applications."

Protecting components from electrostatic discharge is increasingly important, said Megally. "As global trends drive the miniaturisation of electronics, the need to protect components from unintended ESD has become increasingly critical. ESD can cause damage or hidden failures in electronic components, especially during production and transportation."

Cabot's Cabelec compounds and concentrates are used for ESD protection in areas such as electronic carrier trays, crates and boxes. Several new compounds were launched in 2024, including Cabelec CA6830 conductive compound for industrial film applications and Cabelec XS6816A conductive TPU compound, which is a lightweight solution for electronic packaging offering durable ESD protection, consistent conductivity, and superior abrasion resistance for high-wear applications. In the foam segment, Cabelec XS6851A (PP-based) and Cabelec XS6845A (PE-based) conductive concentrates enable

**Main image: Electrification is a growing trend in manufacturing, transportation and other areas**

**Right: Cargill says its Ionphase U5 dissipative additive is designed to provide permanent protection against static in colorable and translucent injection moulding applications**

lightweight electrostatic dissipation with design flexibility for varying electrical properties. Megally said that several customers have already tested and approved the products.

Cabot's Cabelec CA3817 conductive compound for conductive jacketing is meeting needs in the growing cable industry, added Megally. "Global megatrends, including renewable energy generation, the digital transformation, and power grid enhancements, are driving the need for reliable cables capable of managing increased electricity demand and bidirectional energy flow. Conductive thermoplastic compounds play a critical role in meeting these demands, offering solutions for energy transfer, grounding, and shielding," she said.

In packaging and in automotive applications, there is a growing demand for using recycled polymers. Megally said that Cabot's concentrates are being successfully used in applications with recycled content.

The medical and healthcare market has traditionally been one that requires prevention of static buildup to maintain cleanliness, avoid risk of spark in a potentially explosive environment (ie, in an ATEX environment), and in some cases maintain functionality. Pipette tips in automated liquid handling, for example, have stringent requirements, says compounder **Premix**, which displayed its PRE-Elec PP compounds at NPE 2024 in a demonstration on Sumitomo Demag injection moulding equipment.

Premix, which is headquartered in Finland, announced in October 2024 that its Rajamäki site received ISO 14001 certification for its environmental management systems. In 2024 the company expanded services to North America and has been constructing a greenfield compounding plant in Apple Creek, North Carolina, US, that will double the company's production capacity. The facility is scheduled to begin production in 2025.

**Safety**

**Cargill** says its Ionphase U5 dissipative additive is designed to provide permanent protection against static in colorable and translucent injection moulding applications. It is suitable for reducing the surface resistivity of plastic parts as required to meet various ESD or EX safety standards or for dust prevention. The technology is permanent, non-migrating, halogen-free and not dependent on ambient humidity to function.

In electronics packaging, the Ionphase U5 additive reduces ESD risk. In applications where living hinges are employed such as silicon wafer

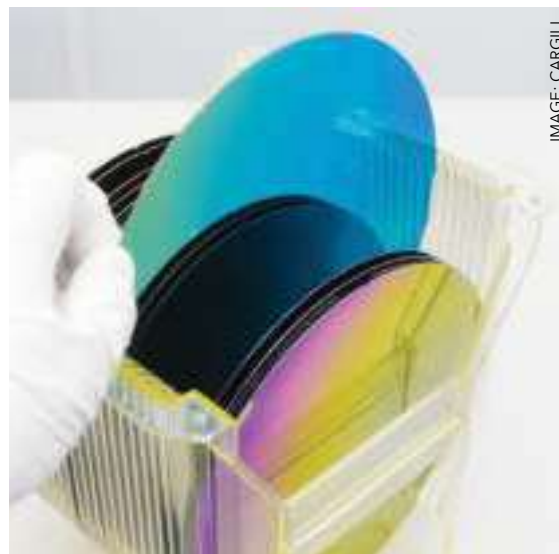

IMAGE: CARGILL

boxes, the additive improves the impact strength of the material and has been shown to have minimal contribution to stress whitening, where other static control solutions are known to cause brittleness, says Cargill.

Ionphase U5 is suited for use in PP but it can also be used in SEBS, SEBS-PP and TPE, and in biopolymers such as PLA, PBAT and PBS. Additional grades of Ionphase static dissipative polymeric additives are available for compatibility with other resins or for use in films.

Carbon black supplier **Orion** offers a wide range of carbon blacks, including those designed for formulating electrically conductive or antistatic thermoplastic compounds. These specialty conductive carbon blacks have a balance of specific surface area and structure, which enables the additive to effectively create a conductive pathway (ie, percolation) in the compound at a low concentration.

Orion's Printex kappa 100 Beads acetylene-based conductive carbon black additives provide both colour and conductivity for wire and cable as well as pipe, film, fibre, packaging, and automotive applications. The company says the product offers excellent dispersibility and high cleanliness, purity and conductivity, which makes it particularly suitable for high-voltage electric transmission cables.

The company currently produces high-purity acetylene-based carbon blacks at a facility in France and is building a second and much bigger facility in La Porte, Texas, US, that will begin operation in late 2025. Jennifer S. Stroh, Orion Vice-President of Sales and Marketing for the Americas, explained that the feedstock is a waste-stream from Texas refineries and the acetylene process is highly efficient, both of which reduce carbon footprint significantly if compared to

Cathay Biotech Inc. will showcase  
Automotive Lightweighting  
Solutions at JEC WORLD 2025

Booth number: **Hall 5 L02**

**Leading Bio-based Polyamide Solutions**  
Thermoplastic Composites | Engineering Plastics

Renewable Raw Material

Low Carbon Emission

Competitive Cost



Website



LinkedIn

Sales Contact

Europe: eu.service@cathaybiotech.com

USA: us.service@cathaybiotech.com

**>50%**

Carbon Footprint Reduction  
(Comparing to Conventional  
Chemical Products)

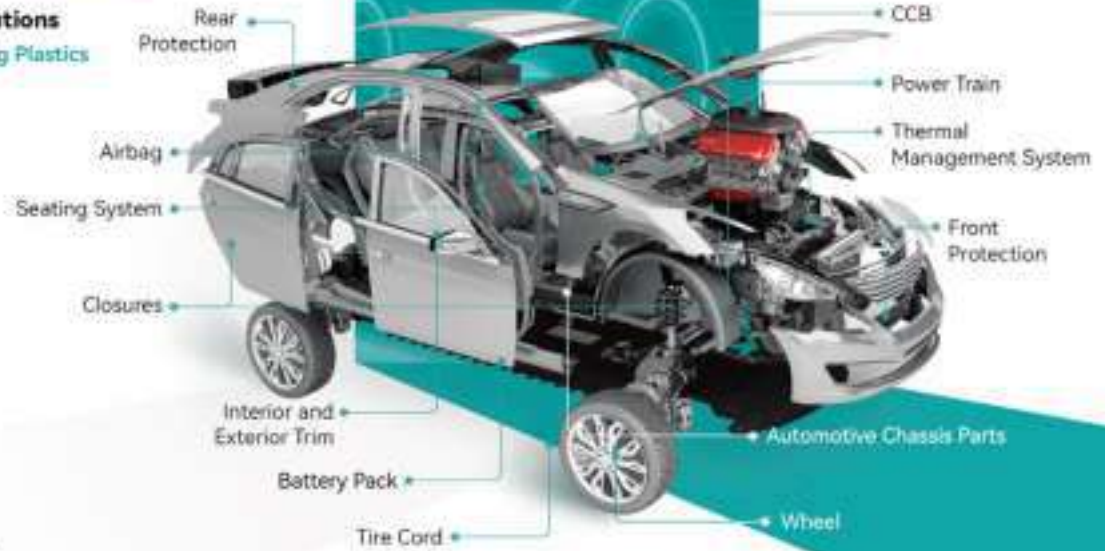

Products for all industries

**Our products shape your business,  
regardless of position in the supply chain**

Dataset

## Global Masterbatch Data

Comprehensive demand and production data for black, white, colour, and additive masterbatches by region and/or country. [Find out more >>](#)

Database

## Plastics Processors Worldwide

A practical tool for sales and marketing teams and top management, aiding in planning sales objectives and allocating resources. [Find out more >>](#)

Dataset

## Global Polymer Demand Data

A powerful data analysis tool crafted to enhance your efficiency in analysing polymer markets, save you valuable time, and support your strategic plans.

[Find out more >>](#)

Contact me to discuss your  
data requirements

Astrid Della Porta  
Commercial Manager  
Market Intelligence  
M/ +44 (0) 7704 389 944  
E / astrid.dellaporta@amiplastics.com



P F A S

AMI | Events

# PFAS Workshop Europe

2-3 June 2025 | Brussels, Belgium

It has never been more important to understand how you'll be affected by potential PFAS bans across Europe

## Confirmed speakers:



**Richard Shepherd**  
Senior Consultant  
AMI



**Alan Taylor**  
Technology Fellow  
TWI



**Yuriko Iida**  
Chief Global Officer  
Emulsion Flow  
Technologies



**Andrea Castrovinci**  
Professor of  
Polymeric Materials  
SUPSI

**BOOK YOUR PLACE IN BRUSSELS**

conventional specialty carbon blacks.

"We are excited to bring this availability to the Americas and to partner with companies who have previously had to import acetylene-based carbon black," said Stroh. "We see a growing interest in conductive blacks at every level - from ESD through to true conductivity."

Orion introduced new specialty carbon black grades at NPE 2024 made from end-of-life tyre pyrolysis oil, which uses waste tyres as a feedstock and creates circular carbon black that can be certified by ISCC Plus. Orion offers ISCC Plus certification for multiple furnace-black grades made from different feedstocks at five different plants. "ISCC Plus verifies the transparency and traceability of sustainable raw materials in our value chain," said Orion CEO Corning Painter in the press release. In June 2024, Orion announced that it was installing additional tyre pyrolysis oil tanks at its plant in Poland to increase production of circular carbon black.

Stroh added that companies have a variety of goals for sustainability, including reducing their carbon footprint at their manufacturing sites, reducing carbon footprint of their products, and having recycled and sustainable sources for raw materials. "Companies have aggressive goals for the 2030 timeframe and beyond, and these new grades will help our customers meet their goals," she said.

Orion says it is continuously expanding its portfolio of conductive additives for cable applications to meet the increasing requirements in terms of dispersion and cleanliness without losing the focus on sustainability. "Over time, we've optimised the colloidal properties of legacy

conductive additives to ensure excellent dispersibility and product cleanliness in our newest grades plus those in development," said Kevin Milks, Orion Marketing Manager for Polymers and Special Applications, in a press release.

### Bio-based black

US-based **Bioregion Technology** (BRT) has launched a series of bio-derived carbon additives produced from lignocellulosic biomass from agricultural waste. The additives have been through the USDA's BioPreferred certification process and have 100% bio-based carbon content, said Brendon Bohnert, Senior Manager for Emerging Technologies at **Nagase**, which has

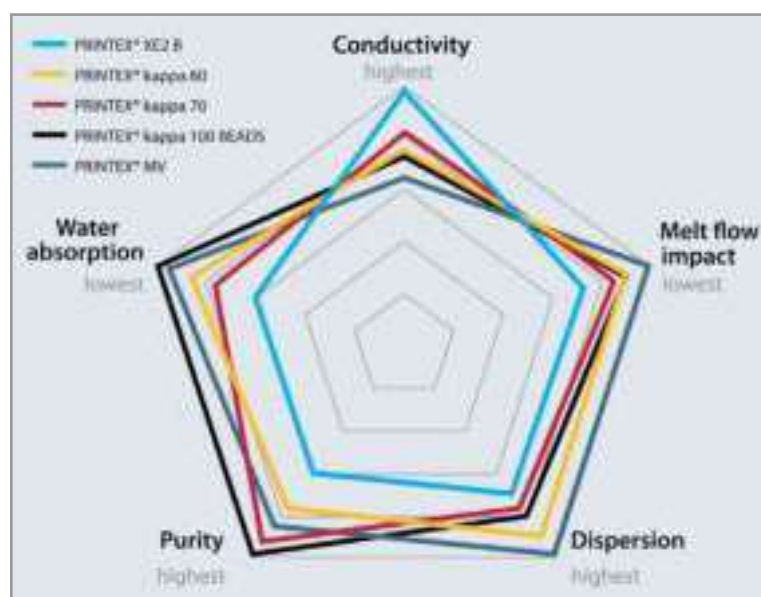

Comparison of selected carbon blacks based on key characteristics relevant for the conductive compound

Source: Orion

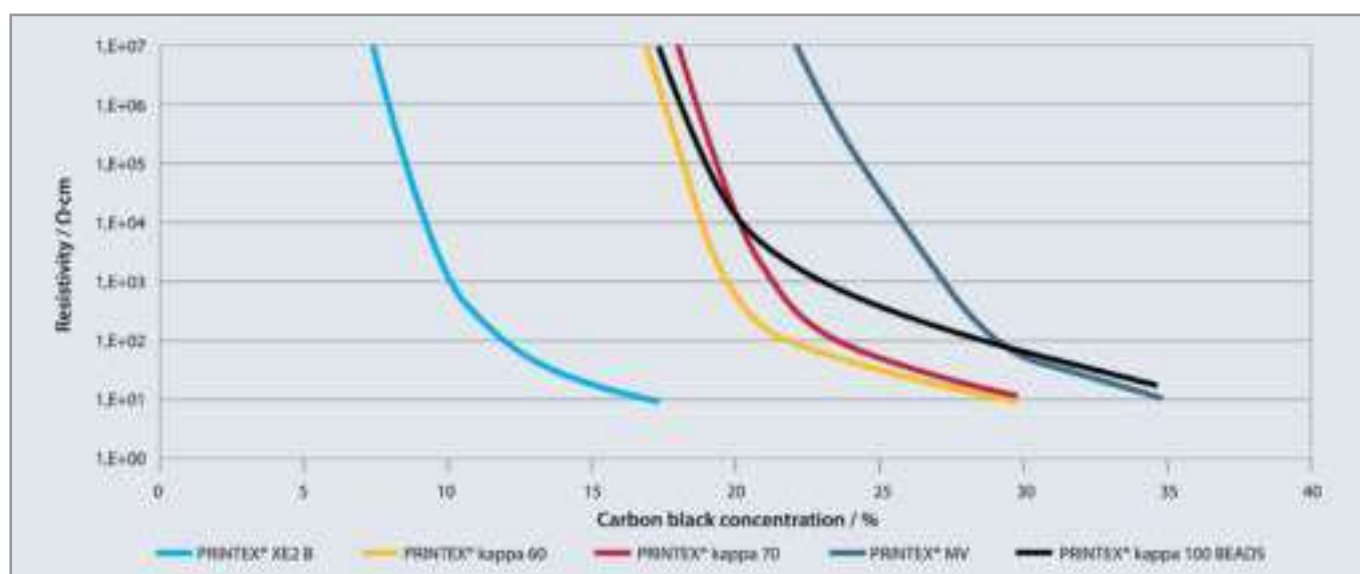

Percolation curves will differ depending on the polymer and process used. Below example of the performance of different conductive carbon blacks in PE-LD injection molded plaques

Source: Orion

partnered with BRT to sell and distribute the additive globally.

“Through a novel carbonisation process, we’re able to turn this abundantly produced and tightly controlled biomass input into a high quality bioderived carbon,” said Bohnert. A patent-pending technology controls surface morphology.

BRT’s product for conductive applications is TruBlack ESD, which can be combined with other additives to support control of surface resistivity in the ESD range in finished plastic parts. It can be used, for example, along with a conductive carbon black or carbon fibre in moulded PP as well as other plastics, to tailor ESD values, said Bohnert.

BRT has built a pilot plant that is capable of producing 1.2m lbs/year of bio-derived carbon, which will be available for both pigment and industrial uses. Next steps include scale up of the process and expansion into conductive applications.

**Delta Tecnic’s** latest is a masterbatch with 75% loading of magnetic fibres for conductive and EMI shielding applications in automotive, electronics, and telecommunications. The company says the masterbatch can be used to make fully formulated compounds or can be used directly in injection moulding.

A key use is EMI shielding in automotive parts, particularly in electric vehicles, where high-voltage cables generate electromagnetic fields that can interfere with other electronic systems, the company says. Other uses are to reduce risk of static discharge in PVC flooring for critical

environments, such as hospitals or electronics manufacturing facilities, and in wheels for industrial trolleys.

The company also supplies conductive PVC compounds using conductive carbon black, carbon nanotubes (CNTs), or graphene as the conductivity additive, depending on the needs of the application. Conductive carbon black typically requires between 15-30% loadings, which can affect physical properties. CNT loadings are in the range of 3-7% and graphene loadings are 2-5%, the company says.

**Additive manufacturing**

**Insight Polymers** launched a product line of concentrates and fully formulated compounds containing CNTs for conductive and ESD parts made using additive manufacturing. “Applications for electronics manufacturing include jigs and fixtures that can be efficiently produced using 3D printing,” said Matt Torosian, Insight Polymers Sales and Market Development Manager. “Dunnage, such as trays and totes for transporting parts, is another application. Anything with a chip in it needs ESD as it is carried through manufacturing.” The new product line includes glass-reinforced PET, PET-G, PC/PBT, carbon-fibre reinforced PEEK, PP and custom products. The concentrates are loaded with 15% CNTs.

In additive manufacturing processes, the formulation must be designed both for good dispersion of the CNTs and for the polymer to print well, typically in either a fused filament fabrication (FFF) or direct pellet extrusion 3D-printing process. “CLTE [coefficient of linear thermal expansion] is



IMAGE: INSIGHT POLYMERS

**Above: Insight Polymers produces concentrates and compounds for conductive applications**

**Compounding System**  
Since 1988



Co Kneader

Twin Screw Extruder

Cable Compounds  
Thermoset Materials  
Masterbatches

www.xindacorp.com info@xindacorp.com





# "ENSŌ" IN MIXING

*looking for perfection*



ITALY PAVILION - STAND 532

*in equipment manufacturing for*

**PVC DRY-BLEND, MASTER BATCH, THERMOPLASTIC RUBBER,  
POWDER COATINGS, METALLIC BONDING and WPC**



**plasmec**  
*Excellence in Mixing*

**PLAS MEC S.R.L.**  
Via Europa 79,  
21015 Lonate Pozzolo (VA) - Italy  
phone +39 0331 301648  
comm@plasmec.it  
[www.plasmec.it](http://www.plasmec.it)

AMI | Events

# Medical Tubing and Catheters

1-2 April 2025 | Düsseldorf, Germany

Improving polymeric medical tubing and catheters, from design, materials and production to applications

Speakers include:



**Andrew Traver**  
Chief Technology Officer  
SIS Medical



**Monika Kriete**  
Marketing Manager  
Lubrizol



**Joan Besolí**  
Plastic and Metal Parts  
Manufacturing Director  
iVascular Global



**Linus Dahlblom**  
Senior Engineer Extrusion  
Development  
Optinova



**Christian Heiner**  
Project Manager  
Ospka

Headline sponsor



Also sponsored by:



**AsahiKASEI**



VIEW THE AGENDA AND BOOK TODAY

key, because as you build up the layers, you need minimal shrinkage of each layer," said Torosian. Additives, fillers and other modifiers are used in the formulations to reduce shrinkage and achieve better bonding between layers. The company measures CLTE and layer-to-layer adhesion as well as impact resistance and bulk and surface resistivity in its in-house development lab.

In addition to the current FFF capabilities in its R&D lab, the company is adding desktop-sized, small-batch 3D-printing filament creation with automated diameter and ovality control that will enable it to make high quality parts for accurate testing and faster development of new products. The company plans to also develop conductive concentrates and compounds for injection moulding applications.

### New nanotubes

Israeli company **Nemo Nanomaterials** has introduced several series of NemoBlend SWCNT [single-wall CNT] masterbatches. The PA6000 series offers electrical conductivity and EMI shielding in PAs, for enclosures, for example. The PE1000 series offers electrical conductivity for PE extrusion applications, such as cables and pipes, and for moulding applications. The PP2000 series provides electrical conductivity in PP. The PS4000 series enhances electrical conductivity in ABS or PS, such as in battery covers for electric vehicles. The company reports that it is also developing masterbatches of CNTs with other nano-carbons and halogen-free flame retardants.

**TrimTabs**, a Wales, UK-based process technology company, is developing a new low-cost, continuous method of producing CNTs from hydrocarbons, including carbon from both pigmented and unpigmented plastic waste, that it plans to bring to commercial scale as micro-factories in a geographically distributed format to aid supply security. TrimTabs CNTs are designed for use in multiple application areas, including thermoplastics.

In automotive thermoplastics, for example, CNTs can be used to make lighter, stronger parts with electrostatic dissipative properties. Other thermoplastic applications are looking for EMI shielding properties or for both electrical and thermal conductivity. The company currently supplies its CNTs as powder but has made masterbatches on a research scale.

### Graphene compounds

Canadian graphene producer **NanoXplore** has recently introduced a new series of graphene additives, produced using a highly efficient, proprietary, dry processing method. These additives are available as powder or masterbatch, and they feature exceptionally high surface areas - 0X-300 and 0X-500 (300 m<sup>2</sup>/g and 500 m<sup>2</sup>/g, respectively) - and high conductivity. The new graphene performs better than existing graphene powders in electrical properties, although the earlier graphene additives excel in thermal conductivity and

[www.compoundingworld.com](http://www.compoundingworld.com)

## FOCUS SCREW | BARREL | SHAFT

Introducing Swiss Splined Shaft Cold Rolling Technology (Non-Milling Machining)

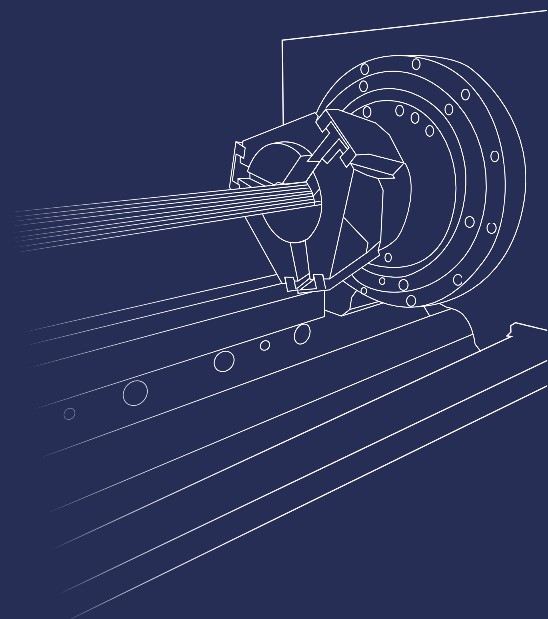

High-load torque / High precision /  
High efficiency / Excellent surface finishes

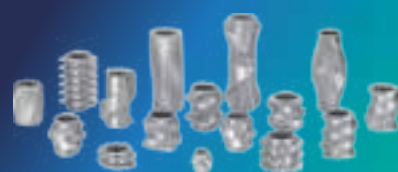

**Nanjing Lesun Screw Co.,Ltd.**

E:info@lesunscrew.com    www.lesunscrew.com



**Above: Graf-X graphene nanoplatelets from NeoGraf provide electrical conductivity for applications requiring low loadings**

other properties, the company says.

Compared to traditional carbon black, the new, dry-processed graphene significantly improves processability in thermoplastics, which allows for faster production throughput while maintaining excellent electrical properties, particularly at high loadings, over 15% by weight, the company reports. These properties make the additive useful for high-throughput applications, such as packaging for static dissipation. The new graphene also has lower greenhouse gas emissions than conventional carbon blacks.

Graphene producer **Versarien** is developing the Polygrene-E family of electrically conductive compounds that can be tuned for static dissipative or EMI shielding properties. These compounds have higher loadings to achieve percolation. Because graphene is not abrasive, higher levels can be used without damaging equipment. Versarien is also experimenting with combinations of fillers, including combinations of graphene with magnetic particles. The company continues to seek collaborative partners to develop graphene compounds and masterbatches.

Graf-X graphene nanoplatelets from **NeoGraf** provide electrical conductivity for applications requiring low loadings. "These materials, consisting of 10-100s [of] graphene layers, achieve percolation thresholds at just 1-10 wt% loading, depending on the polymer and processing method," said R&D Director John Swanson. He notes that the processing method is crucial in dispersing and aligning fillers and that the process should be controlled to avoid damage to the graphite flake structure (ie, reducing the aspect ratio), which can reduce conductivity.

"In addition to pure graphite, our customers are increasingly exploring hybrid approaches, combining graphite with other additives, such as

carbon black, to boost electrical conductivity while minimising total additive loading synergistically," said Swanson. "Another emerging trend involves functionalising graphite with surface modifications to enhance compatibility with polymer systems. However, over-functionalisation must be managed carefully to avoid insulating effects that counteract the desired conductivity improvements. At NeoGraf, we work closely with customers to customise particle sizing, purity, and surface properties, ensuring optimal performance for their specific applications."

Technical compounder **Eurotec** produces permanent conductive compounds using a wide range of polymers, additives and reinforcements to develop grades with a wide range of properties such as colorable, metal detectable or flame retardant. Eurotec provides compounds from anti-static to EMI/RF shielding level. Dissipation of accumulated electrostatic charges is very critical for safe transportation of electronic equipment, for which the company produces Tecolen CP20 BK EC 0C, a PPCP conductive compound, which has static dissipative characteristics suited for ESD crates for electronic devices.

Eurotec says that EV sensor housing materials should have a good mechanical stiffness, creep and fatigue resistance, dimensional stability and EMI/RF shielding properties to avoid any safety issue.

Developed using its know-how in electrically conductive plastics, Eurotec's electrically conductive and structural materials are especially suited to sensor components. It says Tecomid NB30 GR20 BK EF PA6 (a 20% glass fibre-reinforced, electrically conductive, black compound) has satisfied conductivity and mechanical property requirements and is currently used for brackets and housings of electronic sensors by a well-known OEM in order to prevent failure during driving.

**CLICK ON THE LINKS FOR MORE INFORMATION:**

- > [www.cabotcorp.com](http://www.cabotcorp.com)
- > [www.premixgroup.com](http://www.premixgroup.com)
- > [www.cargill.com](http://www.cargill.com)
- > <https://orioncarbons.com>
- > <https://bioregiontech.com>
- > <https://nagaseamerica.com>
- > <https://deltatecnic.com>
- > <https://insightpolymers.com>
- > <https://nemonano.com>
- > [www.trimtabs.co](http://www.trimtabs.co)
- > <https://nanoxplore.ca>
- > [www.versarien.com](http://www.versarien.com)
- > [www.neograf.com](http://www.neograf.com)
- > [www.eurotec-ep.com](http://www.eurotec-ep.com)

# Polymers in Cables

June 10-11, 2025 | Tampa, FL, USA



## To speak, sponsor or exhibit contact

Matthew Dowler  
Event Sales Manager  
E/ matthew.dowler@amiplastics.com  
T/ +1 484 258 2622

# Secure your place for the next edition

## Save 15%\*

off your delegate place if you  
book before March 21, 2025

**Book your place today at:**

[www.ami.ltd/cables-USA-book](http://www.ami.ltd/cables-USA-book)

\*Valid off full price. Discount cannot be retrospectively applied or used in conjunction with any other offer.

## AMI Databases

# Compounders and Masterbatch Producers Worldwide

🔗 Compounds, additives & masterbatch

Unlock business potential with our comprehensive database of contact and production information for 2,500+ plants across seven regions:

- > ASEAN countries: 279 sites
- > China: 348 sites
- > Europe: 742 sites
- > India: 338 sites
- > Middle East and Africa: 250 sites
- > North America: 465 sites
- > South America: 140 sites
- > South East Asia: 276 sites

[Click here to request your free sample](#)



**Contact me to discuss your  
database requirements**

Evren Akfirat  
Business Unit Manager  
- Databases

T / +44 117 314 8139  
E / [evren.akfirat@amiplastics.com](mailto:evren.akfirat@amiplastics.com)



# AMI Plastics World Expos NORTH AMERICA



November 12-13, 2025 // CLEVELAND, OHIO, USA

Confirmed exhibitors include:



Brought to you by:



Co-located exhibitions:



## BOOK YOUR BOOTH HERE



and many more. See the full list of exhibitors [here](#).

Proudly supported by:

**Compounding**  
WORLD

**Film and Sheet**  
EXTRUSION

**Pipe and Profile**  
EXTRUSION

**Plastics Recycling**  
WORLD

**Injection**  
WORLD



AMI | Events

# Bioplastics

August 26-27, 2025 | Cleveland, OH, USA

Exploring the latest in bioplastic technologies  
and applications for a greener tomorrow

Mark your calendars and book your place

Sponsored by:



AMI | Events

# Cables Asia

18-19 November 2025 | Bangkok, Thailand

New for 2025 - join us to explore the  
latest polymeric material innovations  
for cables and wires in Asia

**BOOKING NOW OPEN**



# Advancements in pelletising systems



IMAGE: SHUTTERSTOCK

## *New technologies and trends in pelletising equipment focus on energy reduction, automatic operation and pellet quality. Chris Saunders reports on new products*

The increasing industry-wide emphasis on sustainability means pelletising systems are constantly evolving to meet the challenges of processing conventional plastics with increased recycled content as well as emerging bioplastics. The latest examples are also incorporating more automation to optimise the process and further boost efficiency. Sensors track parameters such as extrusion temperature, pressure, and pellet size, enabling manufacturers to monitor production and make adjustments in real time, reducing waste and ensuring consistent quality. Energy consumption is still a significant concern, especially with large-scale operations, but optimised extrusion processes and advancements like variable-speed motors have led to a marked reduction in energy use.

Prior to 2021, long-established Italian technical compounder **Lati** was having to cope with rising energy costs, a shortage of skilled workers and increased competition. The company needed to increase productivity and reduce expenditure and decided to take a new approach by adopting

pelletising systems from Swiss machine manufacturer **Maag**, which has extensive experience in the pelletising business. In the dry-cut strand pelletising sector alone, the company has introduced over 10,000 machines to the market. Lati, which until then had developed machinery in-house, began using a Maag Primo Plus dry-cut strand pelletiser at its headquarters in Gornate Olona, Lombardy, and the advantages soon became apparent. Diego Imbrighi, Director Technology Innovation at Lati, said: "The major limit on cutting systems developed internally was the life of the cutting rotor in relation to the flow rates and quantities produced. Within a few months we saw that the new strand pelletiser was able to process the required high volumes very reliably with an excellent pellet cut quality."

Lati says that thanks to significantly longer service lives, less maintenance, and optimised pellet geometry, it has been able to raise pellet quality and make the overall production process more efficient. Since the initial trial, the company

**Main image:**  
**New equipment developments aim to enable compounders to control pellet quality**



**Above: Maag developed its semi-automatic single-belt EBG pelletising system for compounding sensitive, highly filled, or brittle products**

has invested in more Maag systems and says it is now likely to phase out its in-house pelletisers altogether. One of the latest additions to its range is the newly-developed semi-automatic single-belt pelletising system (EBG), specially developed for compounding sensitive, highly filled, or brittle products, which are becoming increasingly common in the current climate due to increased use of inhomogeneous recyclates as raw materials. A notable feature of the EBG system is that the polymer strands from the die plate are deposited on a short, movable water or air-flushed chute, which makes commencing production much easier. The polymer strands then run on a metal or plastic take-off belt, meaning that transport from the nozzle head of the discharge machine to the granulator takes place without interruption. A significant advantage here is that if strands break during operation, the product is automatically fed back into the granulator.

Ongoing production is monitored by smart sensors in the feed area, and if there is a disruption in output from the extruder, it is automatically shut down and a message sent to the control system. Another advantage is that elastic, rubbery, and flexible polymers can be handled easily and safely with the belt feed, which is especially useful when producing small batches with frequent product changes. In terms of flexibility, both Lati and Maag agree that the EBG system fits seamlessly into various compounding set-ups.

The cooling rate directly impacts pellet quality, with faster cooling times resulting in harder and more uniform specimens. Although some compounds are only cooled with air, the EBG offers further flexibility for the cooling nozzles, as they can be

operated with a light water mist or more intensive spray if required. Combinations of air and water are also possible. Maag maintains that strand pelletising itself offers clear advantages in terms of operating costs per kg of product compared to underwater pelletising systems, especially with smaller batch operations and short production runs or when using abrasive compounds which can cause high levels of wear.

In January, Maag said that it signed a deal with Carter Day International's petrochemical division to buy certain technology assets. The acquired drying technology will become part of Maag's product portfolio, providing additional high-capacity solutions in the group's pelletising systems.

**PVC systems**

**Coperion** has extensive know-how in the production of pelletisers, and is another company with the capabilities to tailor its systems to meet specific requirements. For example, at Wire 2024 in Düsseldorf, Germany, the company presented what was billed as an 'economical and reliable' PVC compounding and pelletising solution using a Kombiplast KP Two-Stage Compounder in tandem with an Eccentric Pelletizer EGR. The Kombiplast KP combines a ZSK twin screw extruder with a single-screw discharge screw ES-A for gentle pressure build-up of shear-sensitive products, and the EGR is connected to the ES-A to ensure an even material flow through the die plate. The design allows easy integration of a screen changer and an efficient pellet transport, while the optimised knife rotor minimises the dust content of PVC pellets. The system set-up is characterised by very gentle operation and short residence time, while increased flexibility in terms of product changes and machine modifications make it particularly versatile.

"Coperion is a long-standing partner of cable manufacturers and provides an ideal solution for different requirements and a variety of cable compounds," said Matthias Link, Business Segment Manager, PVC & Cable compounds at Coperion. "Manufacturers benefit from long-term experience,

**Right: Coperion has developed a PVC compounding and pelletising solution using a Kombiplast KP 76 Mv PLUS 250 in tandem with an Eccentric Pelletizer EGR**

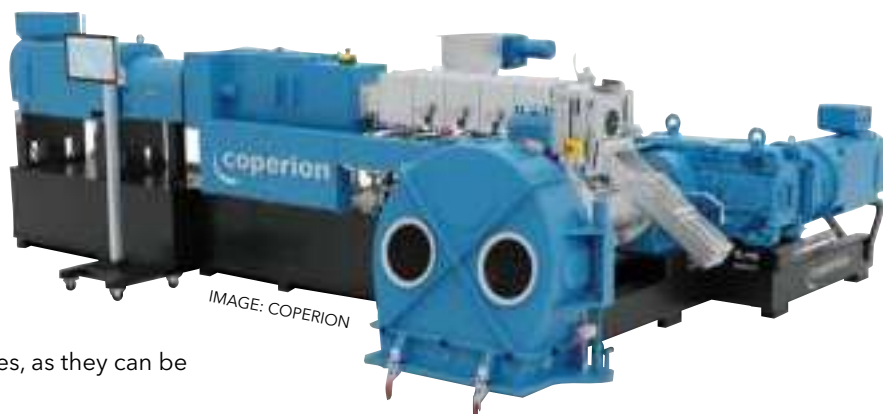

# TEXTILES RECYCLING EXPO

4-5 June 2025 • Brussels, Belgium

The leading platform  
for the textiles  
recycling industry

Register  
for your  
**FREE**  
ticket today



Discover 100 innovations  
transforming textile recycling



Network with like-minded  
industry professionals



Explore a comprehensive  
conference programme

## GAIN INSIGHTS INTO:

Evolving EU Initiatives

Circular Economy Principles

Advanced Recycling  
Technologies

*And Much More!*



[www.textilesrecyclingexpo.com](http://www.textilesrecyclingexpo.com)

# AMI | Events Chemical Recycling

March 11-12, 2025 | Dallas, TX, USA

HEADLINE SPONSOR



Join us next month! Refresh your knowledge, create new connections and establish collaborations with influential players

Hear from industry leading speakers including:



**Silke Einschuetz**  
AMI



**Dr. Carlos Ludlow-Palafox**  
Greenback Recycling  
Technologies



**Ley Richardson**  
Syre



**Brian Bauer**  
Resynergi



**Adam Peer**  
American Chemistry  
Council



**Nousha Tayefeh**  
Emerson



**Dr. Fabio Silvestri**  
Gr3n



**Delphine Largeteau**  
Schneider Electric

Sponsored by:

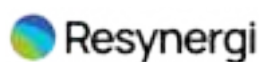

Supported by:



SECURE YOUR PLACE TODAY

comprehensive process know-how, and technology that achieves the highest product quality and maximum economic efficiency.”

Several years after its initial introduction, compounders are still finding new ways to harness the strengths of **Farrel Pomini’s** Continuous Mixer (FCM). Key features of continuous mixing technology include adjustable mixing intensity achieved by changing rotor speed and orifice position, and enhanced temperature control throughout the mixing chamber, rotors, and extruder barrel. The standard 6 L/D rotor provides a short residence time and low heat history which is especially important for processing temperature sensitive PVC.

Rigid PVC is commonly used in construction materials such as decking, rails, window frames, and pipe fittings. Unlike flexible or semi-rigid PVC, it does not contain plasticisers, making it more challenging to process. The traditional processing method involves mixing with batch or continuous compounding equipment finishing with a two-roll mill. Farrel Pomini says that utilising a mill has disadvantages, being difficult to operate and maintain, requiring a long set-up time, and having a large physical footprint.

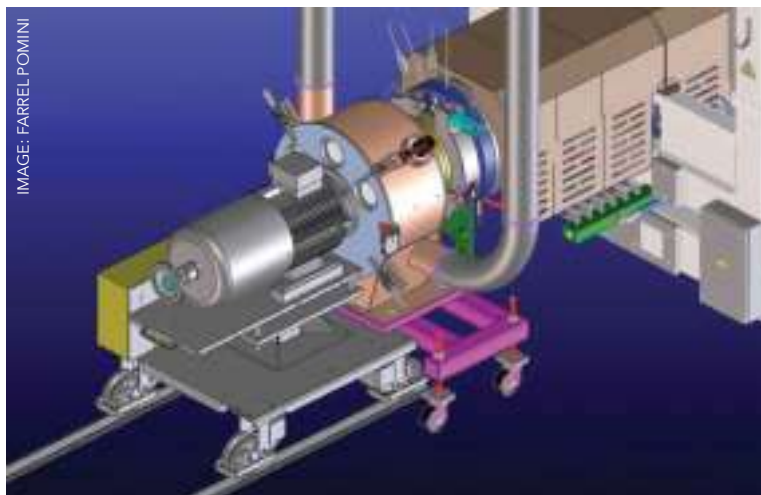

Farrel Pomini’s rigid PVC solution involves compounding the virgin or recycled PVC with the FCM to a hot feed single screw extruder for pelletising. The compound cools as it is processed, while the newly designed Farrel Pomini Dry Face Pelletizer (DFP) minimises die pressure and potential temperature increases, and then efficiently cuts the pellet. After pelletising, an air transfer system completes the cooling process and carries out pellet classifying and dust/fines

**Above: The Farrel Pomini Dry Face Pelletizer (DFP) minimises die pressure and potential temperature increases**

# SPREAD THE WORD

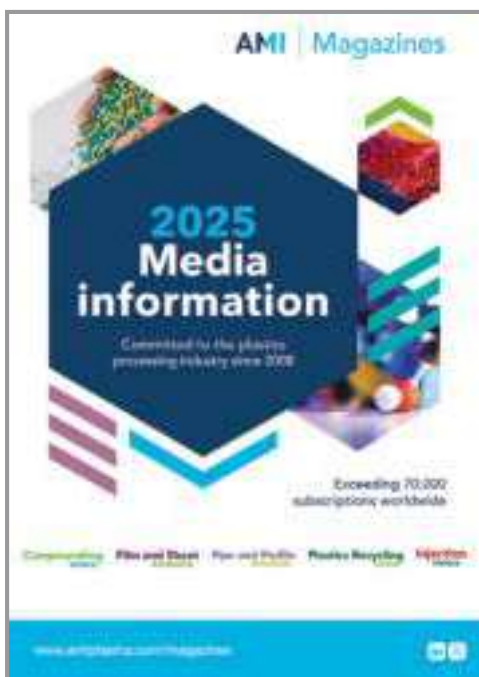

Let the world know about the good things your company is doing by advertising in *Compounding World* magazine. Request the media pack to find out about our forthcoming features, global readership, and cost-effective advertisement packages.

[CLICK HERE TO DOWNLOAD](#)



## IPS breaks new territory

German consultant and solution provider **IPS Intelligent Pelletizing Solutions**, which celebrated its 25<sup>th</sup> anniversary in 2023, has reinforced its growth strategy in Europe by acquiring Kotraco to act as a representative in the Benelux countries. The sales partner, based in Houten, the Netherlands, will now become the central point of contact for customers and partners in Belgium, the Netherlands and Luxembourg.

"After new agencies in Scandinavia, Spain, Poland and South Korea, we are taking the next step in our expansion strategy with the additional agency in the Benelux countries," said IPS Managing Director and owner Gerald Weis. "We are looking forward to working with Kotraco and being represented locally with our solutions for an even broader market."

removal. The DFP has a compact and robust design, is easy to operate, and can be integrated into Farrel Pomini's Synergy Control System, says the company. The entire line can be completely automated with minimal operator involvement, and the system is already commercially available.

### Digital automation

Another company incorporating the latest digital technology is **Bay Plastics Machinery (BPM)** whose new Industry 4.0 smart pelletising system has the ability to store end-to-end process parameters including line and rotor speed, pellet length, activity logs, and maintenance training videos. Users can input material recipes, and the machinery adapts automatically. "The biggest benefit to user recipes is rapid changeovers for customers who run various materials," said Jim Forgash, Vice President of Sales for BPM. "The ability to save process data back into the production line allows for repeatability and ensures the production process is not changed. Our Data Trending page is a historical viewer of process data [which] allows the customer to look back at history to fine-tune the process. Machine settings are used to automatically adjust the user interface to display the appropriate machine limits."

The company is also working on a Preventative Maintenance Log Book which can be used to schedule tasks, mark when maintenance has been completed, and when reoccurring maintenance is due. "This is extremely helpful information for troubleshooting and when looking at the expectancy of wear items such as the feedrolls or rotor blades," Forgash said.

One of BPM's latest innovations is a camera caliper tool to measure diameter. Along with strand count, ovality, pellet length, and line speed, this data

allows BPM to estimate throughput by understanding the physical dimensions of the strand. "In most cases, throughput is determined in pounds per hour, [but] we have the ability to measure the poundage throughput by the minute," Forgash added. "The second control we gain by measuring strand diameter is the ability to maintain a consistent strand width. Using the diameter, we can adjust the line speed on the pelletiser to compensate for variations in the extruder throughput."

Another noteworthy aspect of the new system is its ability to provide access to information through a tablet or computer linked to the control screen where all relevant documentation referring to maintenance and troubleshooting can be found. "Training videos and parts drawings are quickly and easily accessible," said Forgash. "This control system also helps us support customers in non-English speaking countries."

The Smart Control is an option for all BPM strand pelletisers and pelletising systems, and can also be retrofitted onto existing BPM equipment providing it fulfils certain criteria. In addition, the company offers a Smart System that incorporates downstream equipment so that it operates as a whole. "Our newest option is a different take on a manual strand line which we call 'Smart with Auxiliary control.' This system utilises the pelletiser as the main controller, but allows integration with auxiliary equipment such as a water bath or an airknife," said Forgash.

### Pellet quality

According to Israeli instrument manufacturer **Inspec.tech**, which offers monitoring and sorting solutions tailored to the needs of various industry players, the pellet industry is currently experiencing a major surge. Statistics seem to back up the claim, with one recent market report (by Maximize Market Research) stating the plastic pellets sector was valued at \$8.04bn in 2023 and is expected to reach \$11.47bn by 2030. Inspec.tech says its expansion into key markets such as the US, China and South Korea, as well as various countries across Europe, underscores the growing demand for its advanced Quality Assurance (QA) solutions.

A recent LinkedIn post by Inspec.tech founder and CEO Nadav Leshem suggested that maintaining consistent quality throughout the pellet supply chain is paramount, yet poses significant challenges for each player in the chain. "For resin producers, ensuring consistent pellet quality and identifying contaminations early in the production process is crucial," he said. "Inspec.tech's real-time defect detection capabilities help identify and

AMI | Events

# Plastics in Electric Vehicles

3-4 June 2025 | Cologne, Germany

Explore how the shift to electric vehicles is creating new opportunities for the plastics supply chain

Discover insights from industry experts including:



**Marco Barbolini**  
Product Manager,  
Propulsion Global  
Röchling Automotive



**Marco Grundler**  
Group Leader Materials  
& Compounding  
Technology  
ZBT



**Buket Turan**  
Technical Marketing  
Manager  
Eurotec

“

*Engaging conference with experienced peers, would definitely go back next year!*

”

Syensqo

\*Discount not valid in conjunction with other offers. Discount ends 7 March 2025.

15% OFF EARLY BOOKING RATE ENDS 7TH MARCH

**Right: Sikora has highlighted the use of its Purity Scanner Advanced system with XLPE pellets**



IMAGE: SIKORA

remove contaminants like gels, foreign objects, and colour variations. This translates to improved product consistency, minimised downstream processing issues, and an enhanced brand reputation built on delivering high-quality resins.”

The post went on to say how the company’s inline monitoring systems help compounders, whose primary concerns are maintaining precise material composition and preventing inconsistencies in pellets, by not only detecting and eliminating purity issues, but also reducing preventive maintenance and the ensuing downtime. Finally, it noted that one of the biggest challenges facing recyclers is the removal of impurities and ensuring consistent pellet quality, saying: “We assist them in assuring constant quality and colour of the manufactured material while automatically stopping flow of additives when quality drops below the acceptable level. This leads to improved plastic quality and increased market competitiveness by offering higher-quality recycled materials.”

Sikora’s Purity Scanner Advanced, which inspects and automatically sorts pellets to remove contaminants, has been firmly established as an essential piece of kit for some time. The system combines X-ray technology with a flexible optical

system and uses up to three cameras depending on the expected contamination and application. All types of plastic pellets can be inspected, but a recent press release from the company highlights its capabilities as the ideal sorting solution for cross linked polyethylene (XLPE) pellets.

Requirements in the XLPE market differ significantly from standard plastics. In addition to the targeted detection and sorting of black specks and yellowing, the seamless detection and sorting of the smallest metal particles is also essential. The fourth generation of the Purity Scanner Advanced sorts impurities in the range of 25 µm, as well as metal particles up to 50 µm in a single pass. It is essential that the material transport and the method of sorting itself do not introduce any additional contamination into the material flow, which is why the Purity Scanner Advanced is fitted with a transport system featuring a stainless-steel channel which can be easily blown out with compressed air.

Another important criterion is the space required. The material flow of XLPE runs by gravity directly from the dust removal on one floor to the sorting area on the next, and the sorting of optical and metallic impurities should be carried out in such a way that as little good material as possible is wasted. This further optimises production processes, ensures the quality of the XLPE material, and contributes to cost-efficient and sustainable production.

**CLICK ON THE LINKS FOR MORE INFORMATION:**

- > [www.lati.com](http://www.lati.com)
- > <https://maag.com>
- > [www.coperion.com](http://www.coperion.com)
- > [www.farrel-pomini.com](http://www.farrel-pomini.com)
- > <https://bayplasticsmachinery.com>
- > <https://inspec.tech>
- > <https://sikora.net>
- > <https://pelletizing.de>

# FOLLOW OUR SOCIAL CHANNELS



Get the latest plastics industry news and analysis

Be first to know when we publish a new edition

**Compounding**  
WORLD

**Film and Sheet**  
EXTRUSION

**Pipe and Profile**  
EXTRUSION

**Injection**  
WORLD

**Plastics Recycling**  
WORLD

[www.twitter.com/PlasticsWorld](http://www.twitter.com/PlasticsWorld)  
<https://uk.linkedin.com/showcase/plasticsworld>



AMI | Events

# Polymer Sourcing and Distribution

19-21 May 2025 | Malaga, Spain

Save 15%\* when you book before 14 February 2025.

Understanding global plastics trends and shaping strategies for success

Hear from industry leading speakers including:



Patrick Ottens  
Ducor Petrochemicals



Martin Rathke  
Biesterfeld Plastic



Eduardo Contreiras  
RAI Global Distribution



Ali Amin-Javaheri  
Knowde



Mary Aiken-Wood  
British Plastics Federation



Esteban Sagel  
Chemical and Polymer Market Consultants

Headline sponsor:



Also sponsored by:



Supported by:



\*T&C's apply and can be found on the [website](#)

# Download these new product brochures

## COPERION: ZSK EXTRUDERS



ZSK twin screw extruders. The benchmark for maximum throughput and highest product quality.

Claimed to set the benchmark for throughput and quality, the ZSK is Coperion's most flexible and highest performance twin screw extruder series. This brochure explains the design features, applications and options.



coperion

[CLICK HERE TO DOWNLOAD](#)

## MIXACO: SPEEDY MIXER



Speedy mixers provide a flexible mixing option for small batch production. Available in sack and drum versions, the two ranges are supported with a full range of mixing tools designed to achieve fast and homogenous results.

[CLICK HERE TO DOWNLOAD](#)

## TA INSTRUMENTS: ANALYTICAL SOLUTIONS



An extensive range of polymer analysis solutions from TA Instruments enable R&D and processing staff to characterise materials at resin, compounding and converting operations, as shown in this 32-page brochure detailing technologies, applications and case studies.

[CLICK HERE TO DOWNLOAD](#)

## CABOT: SPECIALTY CARBON BLACK



This brochure from Cabot details the company's range of Vulcan specialty carbon blacks for formulation of low moisture absorption electrically conductive plastics for applications such as ESD packaging.

[CLICK HERE TO DOWNLOAD](#)

## KLK OLEO: GREEN ADDITIVES



KLK OLEO provides a series of products for industrial application. PALMOWAX and PALMESTER provide a green lubricant solution to polymer processing. TEMEST, PALMERE and PALMERA as green ingredients for PVC additives/plasticiser.

[CLICK HERE TO DOWNLOAD](#)

## SUKANO: BIO-MASTERBATCHES



Switzerland's Sukano offers a full range of bioplastic masterbatches and compounds to allow processors to maximise the performance of bio-based resins such as PLA and PHA and to simplify and speed up processing.

[CLICK HERE TO DOWNLOAD](#)

If you would like your brochure to be included on this page, please contact Claire Bishop [claire.bishop@amiplastics.com](mailto:claire.bishop@amiplastics.com). Tel: +44 (0)1732 682948

# Keep informed: read our latest editions

AMI publishes five process-specific FREE plastics industry magazines. Simply click on the cover below to read each magazine. Or download the issue in the relevant Apple or Android app



**Compounding World December 2024**  
The December 2024 issue of Compounding World looks at strong currents in global markets affecting companies in the flame retardants sector and trends such as recycled content leading the strategies of masterbatch producers.

[> CLICK HERE TO VIEW](#)



**Compounding World November 2024**  
The November issue of Compounding World magazine has a cover story that looks at improvements in bio-based compounds, while other features are on PVC recycling, mixer technology, and black and white pigments/masterbatch, plus a TaipeiPLAS 2024 review.

[> CLICK HERE TO VIEW](#)



**Injection World November/December 2024**  
The November-December issue of Injection World magazine has a cover feature on the growing availability of digital aids to production in injection moulding, while other features cover developments in hot runners and materials handling. Plus there is a Fakuma 2024 review.

[CLICK HERE TO VIEW](#)



**Plastics Recycling World November/December 2024**  
Plastics Recycling World's November-December 2024 edition shows how in-line data can be used to correct imperfect PCR plastics in articles on colour and melt flow, while non-conventional PET recycling processes are also covered.

[> CLICK HERE TO VIEW](#)



**Pipe and Profile Extrusion Winter 2024**  
Pipe and Profile Extrusion's Winter 2024 edition has a cover feature showing how R&D is helping wood-plastic composites continue to improve, while other features are on large-diameter pipe, materials handling products and PVC additives.

[> CLICK HERE TO VIEW](#)

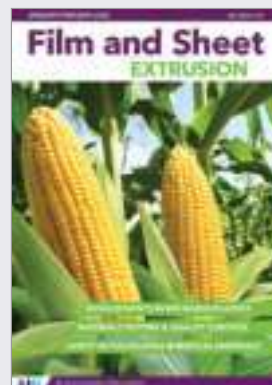

**Film and Sheet Extrusion January/February 2025**  
The January-February edition of Film and Sheet Extrusion looks at how bioplastics producers are broadening the appeal of their offerings for film and sheet companies, plus new materials for medical applications, polyolefin-based developments and a testing/quality control update.

[> CLICK HERE TO VIEW](#)

Take out your own FREE subscriptions to any of the magazines. Click on the logos below to simply register on-line.

**Compounding**  
WORLD

**Film and Sheet**  
EXTRUSION

**Pipe and Profile**  
EXTRUSION

**Injection**  
WORLD

**Plastics Recycling**  
WORLD

**GLOBAL EXHIBITION GUIDE**

2025	<b>11-14 March</b>	Plastimagen, Mexico City	<a href="http://www.plastimagen.com.mx">www.plastimagen.com.mx</a>
	<b>18-20 March</b>	Plastics & Rubber Vietnam, Ho Chi Minh City, Vietnam	<a href="https://plasticsvietnam.com">https://plasticsvietnam.com</a>
	<b>24-28 March</b>	Plástico Brasil, São Paulo, Brazil	<a href="http://www.plasticobrasil.com.br">www.plasticobrasil.com.br</a>
	<b>15-18 April</b>	Chinaplas, Shenzhen, China	<a href="http://www.chinaplasonline.com">www.chinaplasonline.com</a>
	<b>6-9 May</b>	Moulding Expo, Stuttgart, Germany	<a href="https://www.messe-stuttgart.de/moulding-expo">https://www.messe-stuttgart.de/moulding-expo</a>
	<b>7-8 May</b>	PlastTeknik Nordic, Malmö, Sweden	<a href="http://www.plasttekniknordic.com">www.plasttekniknordic.com</a>
	<b>8-10 May</b>	RePlast Eurasia, Istanbul, Turkey	<a href="http://www.replasteurasia.com">www.replasteurasia.com</a>
	<b>14-15 May</b>	Compounding World Expo India, Mumbai	<a href="http://www.compoundingexpoindia.com">www.compoundingexpoindia.com</a>
	<b>14-17 May</b>	Plastics & Rubber Thailand, Bangkok, Thailand	<a href="http://www.plasticsrubberthailand.com">www.plasticsrubberthailand.com</a>
	<b>20-23 May</b>	Plastpol, Kielce, Poland	<a href="http://www.targikielce.pl/en/plastpol">www.targikielce.pl/en/plastpol</a>
	<b>27-30 May</b>	GreenPlast, Milan, Italy	<a href="http://www.greenplast.org">www.greenplast.org</a>
	<b>3-5 June</b>	UTech Las Americas, Mexico City	<a href="http://www.utechlasamericas.com">www.utechlasamericas.com</a>
	<b>4-5 June</b>	Textiles Recycling Expo, Brussels, Belgium	<a href="http://www.textilesrecyclingexpo.com">www.textilesrecyclingexpo.com</a>
<b>8-15 October</b>	K2025, Dusseldorf, Germany	<a href="http://www.k-online.com">www.k-online.com</a>	
<b>4-7 December</b>	PlastEurasia, Istanbul, Turkey	<a href="https://plasteurasia.com">https://plasteurasia.com</a>	

**AMI CONFERENCES**

<b>17-19 February 2025</b>	Polyethylene Films, Tampa, FL, US
<b>25-26 February 2025</b>	PVC Formulation, Cleveland, OH, US
<b>11-12 March 2025</b>	Chemical Recycling, Dallas, TX, US
<b>11-13 March 2025</b>	Cables, Düsseldorf, Germany
<b>11-12 March 2025</b>	Agricultural Film, Malaga, Spain
<b>18-19 March 2025</b>	Compounding and Recycling, Bangkok, Thailand
<b>8-10 April 2025</b>	Stretch and Shrink Film, Malaga, Spain

For information on all these events and other conferences on film, sheet, pipe and packaging applications, see [www.amiplastics.com](http://www.amiplastics.com)

**DON'T MISS A SINGLE ISSUE**

Register now for your free subscription at: [www.compoundingworld.com](http://www.compoundingworld.com)

And don't forget to tell your colleagues, customers and suppliers about the magazine. You can use the share button above (the  symbol in the browser) to help spread the word.

